

5

INTERNATIONAL COUNCIL FOR BUILDING RESEARCH STUDIES
AND DOCUMENTATION
WORKING COMMISSION W18 - TIMBER STRUCTURES

MEETING EIGHT
Bruxelles, Belgium
October 1977

f

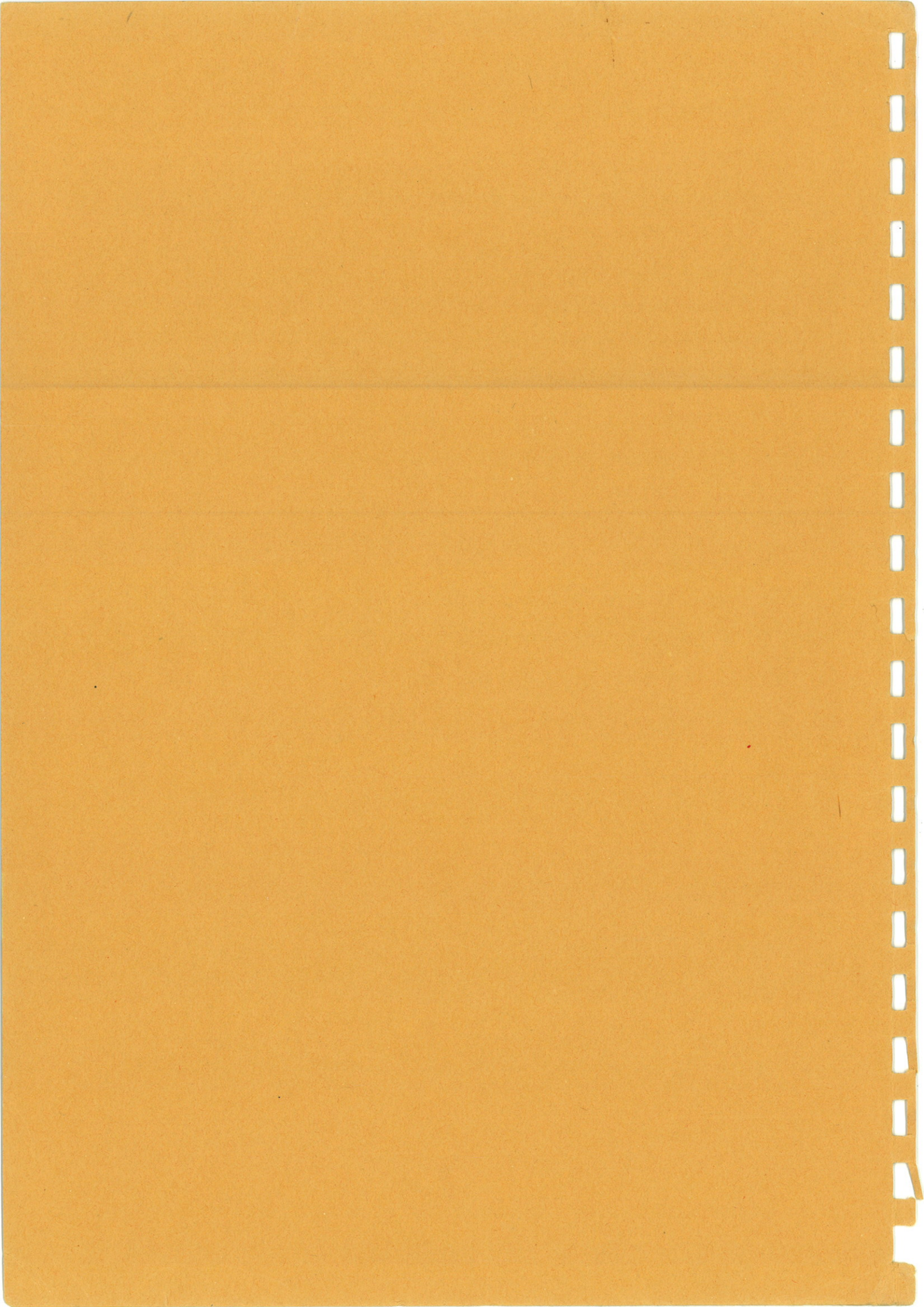

Inhalts-
verzeichnis
S. 12

CONTENTS

	Page
1 List of delegates	2
2 Chairman's introduction	4
3 Co-operation with other organisations	4
4 Structural stability	7
5 Glued laminated structures	7
6 Plywood	8
7 Structural design codes	9
8 CIB Timber code	10
9 Other business	10
10 Next meeting	11
11 Papers presented at the meeting	12
12 Current list of CIB-W18 papers	13
13 Membership of CIB-W18 Timber structures	22

Lehrstuhl für
Ingenieurholzbau u. Baukonstruktionen
Universität (TH) Karlsruhe
Prof. Dr.-Ing. K. Möhler

E 702/776

Standort-Nr.: LH-T218

Nr.: E10218

Lehrstuhl für Ingenieurholzbau
und Baukonstruktionen
Universität Karlsruhe
Univ.-Prof. Dr.-Ing. H. J. Bläß

1 LIST OF DELEGATES

AUSTRIA

E Armbruster European Federation of Building Joinery Manufacturers' Association, Wien

BELGIUM

E Broeckx Institut National du Logement, Bruxelles
A Ingelaere Automated Building Components, Bruxelles
L Montfort Institut National du Logement, Bruxelles

CANADA

C R Wilson Council of Forest Industries of British Columbia, Vancouver

DENMARK

M Johansen Danish Building Research Institute, Horsholm
H J Larsen Aalborg University Centre, Aalborg

FINLAND

U Saarelainen Technical Research Centre of Finland, Espoo

FEDERAL REPUBLIC OF GERMANY

P Frech Otto-Graf-Institut, Stuttgart
H Kolb Otto-Graf-Institut, Stuttgart
K Möhler Technical University of Karlsruhe, Karlsruhe

FRANCE

P Crubile Centre Technique du Bois, Paris

NETHERLANDS

J Kuipers Steven Laboratory, Delft

NORWAY

O Brynildsen Norsk Treteknisk Institutt, Oslo

POLAND

B Bany Centralny Osrodek Badawczo Projektowg, Warszawa
W Nozynski Centralny Osrodek Badawczo, Laskowa

SOUTH AFRICA

T Williams Hydro-Air International, Johannesburg

SWEDEN

B Edlund	Chalmers University of Technology, Göteborg
B Noren	Swedish Forest Products Research Laboratory, Stockholm
B Thunell	Swedish Forest Products Research Laboratory, Stockholm

UNITED KINGDOM

L G Booth	Imperial College, London
H J Burgess	Timber Research and Development Association, High Wycombe
W T Curry	Building Research Establishment, Princes Risborough
P Grimsdale	Swedish-Finnish Timber Council, Retford
R Marsh	Arup Associates, London
1 J G Sunley	Timber Research and Development Association, High Wycombe
2 J R Tory	Building Research Establishment, Princes Risborough

- 1) Chairman and Co-ordinator, CIB-W18
- 2) Technical Secretary

2 CHAIRMAN'S INTRODUCTION

MR SUNLEY the co-ordinator of CIB-W18 and chairman of the meeting welcomed delegates to the eighth meeting of the Commission. He pointed out that the present meeting in Brussels followed the W18 tradition of holding each meeting at a different venue to permit local participation and to stimulate interest in the work of the Commission.

3 CO-OPERATION WITH OTHER ORGANISATIONS

ISO/TC 165: PROF LARSEN, the chairman of TC 165, reported that at the meeting of TC 165 in September it had been agreed that CIB-W18 should provide a draft international timber code for submission to TC 165. Their meeting had accepted for consideration the RILEM/W18 standard for testing joints but had reservations about handling the standards on plywood and structural sized timber since these might possibly be the responsibilities of TC 139 and TC 55 respectively.

DR KUIPERS suggested that the problems of defining areas of responsibility belonged within ISO. The RILEM group, he said, would continue to publish standards and submit draft ISO standards to TC 165 and then TC 165 could decide how they should be dealt with and which other technical committees should be involved.

DR BOOTH said that it would not be desirable for the plywood standard to be passed to TC 139. They had dealt mainly with clear plywood and would not necessarily understand the reasoning behind some of the decisions taken in producing the standard.

DR WILSON said that he would like to see TC 165 handle all structurally orientated standards to avoid confusion between different technical committees.

MR SUNLEY proposed that Prof Larsen, Dr Kuipers and himself, should make personal contact with the chairman of TC 139 to explain the problems, and this was agreed.

PROF LARSEN told the meeting that although a case could be made for retaining structural plywood in TC 165 it was more difficult to justify the retention of testing structural sized timber since TC 55 had already circulated for comment a standard on this subject. He explained that TC 165 would pass the W18 standard to TC 55 but could only take action if TC 55 failed to act.

RILEM 3-TT/CIB-W18: DR KUIPERS, the chairman of this group, reported on the meeting of 3-TT/W18 that had immediately preceded the W18 meeting. He said that the first annexe to the joints standard (on nail plates), the standard on testing structural sized timber and the standard on plywood testing were now ready for publication in the RILEM journal. It was agreed by the delegates that Mr Sunley and Dr Kuipers should together draft introductions to these papers specifically inviting comments within a defined period of time. After comments had been considered by the 3-TT/W18 sub-group the papers should be submitted to the main committee. DR KUIPERS asked the meeting to provide papers on sampling and analysis of data in support of the testing standards and suggested that a paper on the evaluation of test results for joints should be on the agenda for the next W18 meeting.

MR CURRY said that W18 and not the 3-TT/W18 sub-group must decide whether the basis for joint sampling should be density or compression strength.

MR BRYNILDSEN informed the meeting that funds were now available to him for the drafting of a Nordic standard on fasteners but because he was not aware of the latest changes introduced by RILEM the Nordic standard would probably differ from that produced by W18.

MR SUNLEY pointed out that it was unreasonable for members of W18 to agree to proposals at international meetings and then to produce national codes which were different. He reminded delegates that the membership of the 3-TT/W18 sub group could vary to take account of the subjects under discussion and those with particular interests in testing would do well to contact Dr Kuipers.

PROF LARSEN asked the delegates if they agreed with the proposed corner loading method of measuring shear modulus given in the plywood standard. He said that he was still firmly convinced that this test in fact measured torsional stiffness and that there was a difference between these two properties.

2 PROF MÖHLER agreed with Prof Larsen that there were considerable differences between shear and torsional moduli and said that tests in Germany indicated that the ratio between these two properties could be as high as 5:1. 2

DR BOOTH said that he had not been convinced at earlier meetings of the differences between shear and torsional moduli and he thought that for material made up from thin plies the differences would be small. He pointed out that this form of test for shear modulus had been used for many years and in other fields, including the aircraft industry, and no one else had queried its validity. However, Dr Booth agreed that in view of Prof Mohler's observations further tests were required to finally resolve this problem.

MR SUNLEY asked Prof Larsen, Dr Booth and Prof Möhler together to consider the problem but that their deliberations should not delay publication of the suggested standard.

DR KUIPERS wound-up his report on the 3-TT/W18 sub-group by outlining a timetable which would lead to the publication of standards on board materials, joints testing and annexes to joint testing.

IUFRO: MR SUNLEY outlined the program that Dr Foschi, Prof Madsen, Dr Wilson and Mr Pellerin were organising for August 1978. This comprised a conference on Wood Fracture Mechanics, a meeting of the IUFRO Wood Engineering Group and a seminar on Non Destructive Testing. Each of these activities was scheduled to last for approximately one week. Mr Sunley also asked those members of IUFRO present at this meeting of W18 to consider nominations for the co-ordinator of IUFRO as his term in that office had expired.

MR BRYNILDSEN reported on the activities of the IUFRO S5/CIB-W18 sub-group on duration of load and moisture content effects. He said that much of their effort so far had been concentrated on the prediction of strength by matching paired specimens, but results had been disappointing and the best method of predicting strength still appeared to be by measuring E. This meant that groups of thirty specimens would have to be tested rather than matched pairs. He

also reported that preliminary results on the strength to moisture content relation for European spruce supported Prof Madsen's work in this field. The sub-group still lacked funds for these projects. Tentative approaches to NATO had not been very promising since they did not support applied research. There were also problems on finding adequate facilities for the test work. The Canadian facilities would be fully extended for more than three years and no other single laboratory could accommodate the whole test program. However the sub-group was continuing with its work and would soon produce a detailed programme of work for the long-term bending project.

DR WILSON said that Dr Foschi and Dr Barrett were looking at the same problems of duration of load and moisture content in North America. He understood that the Western Forest Products Laboratory had extended their facilities and were now setting up test rigs. He asked if there were possibilities for co-ordination between WFPL and IUFRO/W18.

MR BRYNILDSEN said that he would welcome closer contact with the North American group.

ECE: PROF THUNELL reported on the activities within the United Nations Economic Commission for Europe. There were three areas of interest to W18, he said: the stress grading of coniferous sawn timber; finger jointing and dimensions for sawn timber. Although there had been agreement in ISO some years ago on dimensions there was now some pressure for rationalisation but this would probably not influence the work of W18. The ECE timber committee had now settled the stress grading issue, continued Prof Thunell. There were to be three grades; S10, S8, S6 with visual selection based on the Knot Area Ratio system. In addition there was to be a density limit for the highest grade (S10). The rules for finger joints in structural timber were also accepted. For both stress grading and finger jointing the Timber Committee had made recommendations on how to ensure the entry into service of the standard.

PROF LARSEN asked how density determination was to be carried out.

MR CURRY said that a satisfactory measurement of density was not practicable as part of the visual grading operation and the S10 grade would therefore probably be limited to machine selection.

PROF THUNELL concluded his report by stressing the urgent need for W18 to produce documents on sampling and analysis of test results. He asked for these to be ready before the end of 1978.

PROF LARSEN thought that there should be no problem in the analysis of test results. With samples of greater than 300 he was prepared to rely on engineering judgment to derive characteristic stresses. He suggested that the main problem was one of sampling.

DR NOREN and MR CURRY were agreed that sampling was perhaps the most difficult problem but they pointed out that different methods of interpretation could produce different characteristic stresses from one set of results. It was important to give guidance on methodology to produce consistent conclusions.

MR SUNLEY and MR CURRY drew the attention of the meeting to what they felt was a bias towards European red/whitewood in the proceedings of the ECE. They felt that this bias should be resisted.

4 STRUCTURAL STABILITY

PROF LARSEN introduced paper CIB-W18/8-15-1 "Laterally Loaded Columns" explaining that it looked at the problems that arose with combinations of axial forces and end moments. He apologised that the English translation was not available but undertook to provide this within one month for inclusion in the proceedings.

DR KUIPERS said that he too was interested in this work and hoped that one of his students would soon be preparing a report on combined compression and end moments.

5 GLUED LAMINATED STRUCTURES

DR ARMBRUSTER presented paper CIB-W18/8-12-3 "Glulam Standard Part 1 (FEMIB)". He explained that this first part of a Glulam standard laid down the grading rules for timber for laminating and was the result of agreement between manufacturers from eight European countries.

PROF LARSEN said that the two grades of timber specified by this standard permitted the use of an unacceptably low quality timber.

DR ARMBRUSTER said that the standard was intended to give sensible and practical grading limits that would result in economic use of timber. The lowest grade was not greatly inferior to many of the lower grades at present in use in Europe.

MR FRECH told delegates that there were at present ² three grades for laminating timber in Germany. If they were to lose their top grade with a KAR limit of 0.2 then permitted stresses would be reduced from 140 kgf/cm² to 110 kgf/cm². 2

PROF LARSEN said that he could not accept these grades without supporting stresses which should be based on test results.

MR BURGESS pointed out that the lowest grade in the standard was equal to the lowest UK grade which was also based on KAR and the stresses for that grade were based on tests of individual laminae.

DR ARMBRUSTER asked the meeting for guidance on what testing was required and on how safe stresses should be assigned.

PROF MONTFORT said that a full testing program of complete laminated members would be a very difficult and expensive undertaking because of all the possible combinations and mixtures of grades, number of laminations, jointing etc.

Paper CIB-W18/8-12-1 "Testing of Big Glulam Timber Beams" was introduced by MR FRECH who explained that this short paper summarised the contents of a lengthier test report. He said that the testing had included beams of 30 m length and from these beams had been cut the smaller beams. Predictably coefficient of variation of strength for the beams had been less, at 15 per cent, than would have been expected for solid timber. In answer to questions he said that the beams had been manufactured from finger-jointed grade 1 timber using urea glue. All laminae were 30 mm thick. In several cases failure had originated at a finger joint.

PROF LARSEN pointed out that this paper was one of several in which laminated beams had achieved only 70 per cent of their expected strength. ⚡

MR FRECH agreed with this. A design stress of 14 N/mm^2 with a safety factor of 3 had been used in calculation but the beams had only achieved factors of between 2.2 and 2.5 ie a reduction approximately in the ratio of tension to bending strength. Part of this reduction could be attributed to imperfect finger joints.

PROF MOHLER also agreed that finger joints presented problems. Failure stresses at finger joints were generally about 60 per cent of the failure stresses in unjointed timber. He considered that construction methods should be taken into account in standards for laminated members.

PROF LARSEN favoured a simple approach -- defining performance standards and allowing any material or constructional techniques that would meet those standards. He said that such an approach would have the advantage of avoiding a theoretical basis which could be significantly influenced by changes in production procedures.

MR SUNLEY said that setting performance standards had the advantage of being independent of species and therefore improved the chances of harmonisation in design methods.

MR CURRY did not agree with Prof Larsen; he pointed out that set target stresses had no connection with yields which were commercially important. There would be too much emphasis on what suited European redwood/whitewood and too little on a basic methodology.

MR MARSH found Prof Larsen's system attractive to the practising engineer and asked why such a system could not be adopted for plywood.

MR CURRY and DR BOOTH said that they would not like to see the idea of performance standards introduced to plywood. They felt that such a simple system could have advantages if the relativities between strength properties remained the same for different species but since they did not remain the same there would inevitably be quite serious anomalies for some species of timber. For plywood the very large variety of species, lay-ups and other factors were against the satisfactory implementation of the system.

It was finally agreed that Dr Armbruster, Mr Frech and Dr Edlund should consult together to produce a paper on performance standards or stresses for glued laminated timber.

MR FRECH introduced paper CIB-W18/8-12-2 "Instructions for the Reinforcement of Apertures in Glulam Beams" explaining how the strain around holes in beams had been measured with and without reinforcing. The tests had been conducted on 22 beams and although the optimum thickness of reinforcing plate had perhaps not been achieved they had arrived at acceptable and practicable rules which would have been much more difficult had they had to rely on calculation alone.

DR BOOTH asked if reference could be made to the original report (of which this paper was a summary). Mr Frech agreed to do this.

6 PLYWOOD

Paper CIB-W18/8-4-1 "Sampling Plywood and the Evaluation of Test Results" and appendix 8-4-1A were presented by DR NOREN, who explained that this was an introductory paper to this topic and he invited comments on the content and methods proposed. He pointed out that his choice of 30 for the number of panels to be tested was an arbitrary figure and should really depend on how

the population was defined. He also pointed out that in the absence of contradictory evidence it was assumed that the strength properties of plywood were normally distributed.

DR WILSON told the delegates that in Canada tests were being conducted to evaluate the differences between plywoods made from various species. Advice from statisticians was that at least 60 panels per species would be required to test for differences in the means of 23 species. The number of tests would have to be increased to test for differences in lower exclusion values or if the distributions were non-Normal. Dr Wilson also suggested that the number of tests should depend on whether characteristic stress levels were being established or whether the tests were to check for compliance with an existing standard. In the latter case he would expect that fewer tests would be required.

DR BOOTH agreed with Dr Wilson. He also drew attention to table 6.1 saying that if those values of 'k' were used then stresses would be lower than those in current use.

DR NOREN accepted the comments of Dr Wilson and Dr Booth and said that perhaps this paper was inclined towards compliance testing, but the assumption of normal distributions, which needed further investigation, had been made in establishing existing stresses and there was a better statistical foundation for the factors of table 6.1 than for a fixed $k = 1.64$. However, he pointed out that although he had used a 75 per cent confidence level to formulate table 6.1 the question of confidence levels should not be for W18 to decide.

PROF LARSEN said that distributional functions were not required for the timber code and in any case it had been internationally accepted that all material strengths were log-normally distributed and loads were normally distributed.

MR CURRY did not agree with such sweeping generalities which, he said, were gross simplifications. ✓

PROF EDLUND suggested that rather than discuss the suitability of various distributional functions a non-parametric method could be used.

DR BOOTH said that the most important part of the problem was to agree on a method so that consistently comparable fifth percentile values could be derived by different countries. It was also important to decide whether nominal stresses, actual stresses or load capacities were to be used to define the strength of plywood.

It was agreed that Dr Noren should produce a second draft of his paper, under the title "Sampling of Plywood and the Derivation of Stress Values" and that Dr Booth should produce a paper on the evaluation of test results.

7 STRUCTURAL DESIGN CODES

DR BANY distributed English translations of "Polish Standard PN-73/B-03150: Timber Structures" (CIB-W18/8-102-1). He explained the derivation of the fifth percentile bending stress given in the code and said that this could be modified by factors of 0.67 for long-term loading and 0.4 for size, to produce a working stress of 130 kgf/cm². He told delegates that an approximate comparison with the German code showed that the German code was more conservative.

PROF LARSEN asked Dr Bany if he could provide a short paper on load factors and design procedures that were applicable to Poland. Dr Bany agreed to do this.

A summary of the contents of 'The Russian Timber Code' (CIB-W18/8-102-2) was circulated by the secretary who explained that copies of the complete code were available but unfortunately only in Russian.

8 CIB TIMBER CODE

MR CURRY told the meeting about his interpretation of the JCSS document, published by CEB, "Bulletin D'Information No 116: Volume 1; Common Unified Rules for Different Types of Construction Material" and how he expected difficulties in the adoption of the principles given in this document when they were applied to timber structures. He pointed out that since the code would have to be applied to all structures it would not be possible to avoid conflict with some existing practices and particularly with what could be called traditional forms of construction. Mr Curry found it regrettable but unavoidable that timber should become involved in limit state design where the theoretical ideal of a quantifiable probability of failure could not be achieved.

MR SUNLEY said that limit state codes were being produced for other materials and timber was being pressed to follow suit.

PROF LARSEN reported that the Nordic countries had discussed limit state design for timber and would probably adopt a method 2 approach. They had presented a paper to ECE on this subject which was not based on Volume 1 of the JCSS Code. Prof Larsen said that Volume 1 had been produced by designers of concrete structures and had a definite bias towards concrete practice. It was not acceptable for timber and it was unlikely that it would be adopted by those responsible for steel codes.

MR CURRY said that it was not necessary for W18 to adopt the whole of the content of Volume 1 - there was in any case insufficient information to allow a reasonable interpretation - but the principles could be accepted. Mr Curry also pointed out that loading was not suitably defined by Volume 1 to allow valid comparisons to be made with existing procedures.

MR SUNLEY said that he would take into account the views that had been expressed at the meeting and if asked for comment on Volume 1 by the Joint Committee on Structural Safety would summarise the objections as: inadequate definition of loads and their associated gamma factors; a bias towards concrete that was unlikely to produce harmonisation between materials; insufficient information for a reasonable interpretation.

Paper CIB-W18/8-100-1 "CIB Timber Code: List of Contents (second draft) was distributed by PROF LARSEN. He explained that he had drafted this paper as a response to the request from ISO/TC 165 for a list of contents of the timber code.

|| It was agreed that Prof Larsen, Dr Kuipers, Prof Mohler, Dr Booth and one other should form an editorial group to draft a code. Comments on the List of Contents were invited before 1 December 1977.

9 OTHER BUSINESS

MR WILLIAMS told the meeting that there was an urgent need for an international trussed rafter code. Other delegates agreed that Mr Williams should form a corresponding committee consulting with the International Truss Plate Association and draft a trussed rafter code for consideration by W18.

MR SUNLEY proposed that the secretary should, after minor editorial amendments, submit document CIB-W18-1 "Symbols for Use in Structural Timber Design" to ISO TC/165. This was agreed.

MR SUNLEY closed the meeting and thanked PROF MONTFORT and MR BROECKX, as representatives of the Institut National du Logement, for their hospitality, for the interesting excursions they had arranged and for the facilities that had been made available for the meeting of the Commission.

10 NEXT MEETING

The next meeting of CIB-W18 will take place on 7,8,9 June 1978 in Edinburgh, Scotland. Topics for discussion will include:--

- 1 Sampling of plywood and evaluation of test results
- 2 Glued laminated structures
- 3 CIB Timber Code

The CIB-W18 meeting will be preceded on 6 June by a meeting of the RILEM 3-TT/CIB-W18 sub-group.

Arrangements for these meetings will be made by the Timber Research and Development Association.

11 PAPERS PRESENTED AT THE MEETING

- ✓ CIB-W18/8-4-1 Sampling Plywood and the Evaluation of Test Results -- B Noren
- ✓ CIB-W18/8-12-1 Testing of Big Glulam Timber Beams -- H Kolb and P Frech
- ✓ CIB-W18/8-12-2 Instructions for the Reinforcement of Apertures in Glulam Beams -- H Kolb and P Frech
- ✓ CIB-W18/8-12-3 Glulam Standard Part 1: Glued Timber Structures; Requirements for Timber.
- ✓ CIB-W18/8-15-1 Laterally Loaded Timber Columns: Tests and Theory -- H J Larsen .
- ✓ CIB-W18/8-100-1 CIB Timber Code: List of Contents (second draft) -- H J Larsen
- ✓ CIB-W18/8-102-1 Polish Standard PN-73/B-03150: Timber Structures; Statistical Calculations and Designing
- ✓ CIB-W18/8-102-2 The Russian Timber Code: Summary of Contents
- ✓ CIB-W18/8-103-1 Draft Resolutions of ISO/TC 165

✓
✓
List of CIB-W 78 Papers
Membership of CIB-W18 (Nov 77)

INTERNATIONAL COUNCIL FOR BUILDING RESEARCH STUDIES AND DOCUMENTATION

WORKING COMMISSION W18 - TIMBER STRUCTURES

LIST OF CIB-W18 PAPERS

Bruxelles

October 1977

Lehrstuhl für
Ingenieurholzbau u. Baukonstruktionen
Universität (TH) Karlsruhe
Prof. Dr.-Ing. K. Möhler

12 CURRENT LIST OF CIB-W18 TECHNICAL PAPERS

Technical papers presented to Working Commission W18 - Timber Structures are classified by a code identifying the meeting at which the paper was presented, the subject heading and the number of the paper. The full classification number of a document will start with CIB-W18, although where the context is clear this prefix may be omitted.

Example: CIB-W18/4-102-5

refers to paper 5 (Extract from Norwegian Standard NS 340 - "Timber Structures") on subject 102 (Structural Design Codes) presented at the fourth meeting of W18 (Paris, February 1975).

Published documents emanating from the Commission will simply be numbered in the order in which they appear.

Meetings are classified in chronological order:

- 1 Princes Risborough, England; March 1973
- 2 Copenhagen, Denmark; October 1973
- 3 Delft, Netherlands; June 1974
- 4 Paris, France; February 1975
- 5 Karlsruhe, Federal Republic of Germany; October 1975
- 6 Aalborg, Denmark; June 1976
- 7 Stockholm, Sweden, Feb/March 1977
- 8 Bruxelles, Belgium, October 1977

Subjects are denoted by the following numerical classification:

- 1 Limit State Design
- 2 Timber Columns
- 3 Symbols
- 4 Plywood
- 5 Stress Grading
- 6 Stresses for Solid Timber
- 7 Timber Joints and Fasteners
- 8 Load Sharing

- 9 Duration of Load
- 10 Timber Beams
- 11 Environmental Conditions
- 12 Laminated Members
- 13 Particle and Fibre Building Boards
- 14 Trussed Rafters
- 15 Structural Stability
- 100 CIB Timber Code
- 101 Loading Codes
- 102 Structural Design Codes
- 103 International Standards Organisation
- 104 Joint Committee on Structural Safety
- 105 CIB Programme, Policy and Meetings
- 106 International Union of Forestry Research Organisations

Listed below, by subjects, are all papers that have to date been presented to W18. When appropriate some papers are listed under more than one subject heading.

LIMIT STATE DESIGN

- 1-1-1 Paper 5 Limit State Design - H J Larsen
- 1-1-2 Paper 6 The use of partial safety factors in the new Norwegian design code for timber structures - O Brynildsen
- 1-1-3 Paper 7 Swedish code revision concerning timber structures - B Norén
- 1-1-4 Paper 8 Working stresses report to British Standards Institution Committee BLCF/17/2
- 6-1-1 On the application of the uncertainty theoretical methods for the definition of the fundamental concepts of structural safety - K Skov and O Ditlevsen

TIMBER COLUMNS

- 2-2-1 Paper 3 The Design of Solid Timber Columns - H J Larsen
- 3-2-1 Paper 6 Design of Built-up Timber Columns - H J Larsen
- 4-2-1 Paper 3 Tests with Centrally Loaded Timber Columns -
H J Larsen and Svend Sondergaard Pedersen
- 4-2-2 Paper 4 Lateral-Torsional Buckling of Eccentrically Loaded Timber
Columns - B Johansson
- 5-9-1 Strength of a Wood Column in Combined Compression and Bending with
respect to Creep - B Kålsner and B Norén
- 5-100-1 Design of Solid Timber Columns - H J Larsen
- 6-100-1 Comments on Document 5-100-1, Design of Timber Columns - H J Larsen
- 6-2-1 Lattice Columns - H J Larsen
- 6-2-2 A Mathematical Basis for Design Aids for Timber Columns - H J Burgess
- 6-2-3 Comparison of Larsen and Perry Formulas for Solid Timber Columns - H J Larsen
- 7-2-1 Lateral Bracing of Timber Struts - J A Simon
- 8-15-1 Laterally Loaded Timber Columns: Tests and Theory - H J Larsen

SYMBOLS

- 3-3-1 Paper 5 Symbols for Structural Timber Design - J Kuipers and B Norén
- 4-3-1 Paper 2 Symbols for Timber Structure Design - J Kuipers and B Norén
- 1 Symbols for Use in Structural Timber Design

PLYWOOD

- 2-4-1 Paper 1 The Presentation of Structural Design Data for Plywood - L G Booth
- 3-4-1 Paper 3 Standard Methods of Testing for the Determination of Mechanical
Properties of Plywood - J Kuipers
- 3-4-2 Paper 4 Bending Strength and Stiffness of Multiple Species Plywood -
C K A Stieda
- 4-4-4 Paper 5 Standard Methods of Testing for the Determination of Mechanical
Properties of Plywood - Council of Forest Industries, BC
- 5-4-1 The Determination of Design Stresses for plywood in the revision of
CP 112 - L G Booth

- 5-4-2 Veneer Plywood for Construction - Quality Specification - ISO/TC 139 - Plywood, Working Group 6
- 6-4-1 The Determination of the Mechanical Properties of Plywood Containing Defects - L G Booth
- 6-4-2 In-grade versus Small Clear Testing of Plywood - C R Wilson
- 6-4-3 Buckling Strength of Plywood: Results of Tests and Recommendations for Calculations - J Kuipers and H Ploos van Amstel
- 7-4-1 Methods of Test for the Determination of the Mechanical Properties of Plywood - L G Booth, J Kuipers, B Norén, C R Wilson
- 7-4-2 Comments on Paper 7-4-1
- 7-4-3 The Effect of Rate of Testing Speed on the Ultimate Tensile Stress of Plywood - C R Wilson and A V Parasin
- 7-4-4 Comparison of the Effect of Specimen Size on the Flexural Properties of Plywood using the Pure Moment Test - C R Wilson and A V Parasin
- 8-4-1 Sampling Plywood and the Evaluation of Test Results - B Norén

STRESS GRADING

- 1-5-1 Paper 10 Quality specifications for sawn timber and precision timber - Norwegian Standard NS 3080
- 1-5-2 Paper 11 Specification for timber grades for structural use - British Standard BS 4978
- 4-5-1 Paper 10 Draft Proposal for an International Standard for Stress Grading Coniferous Sawn Softwood - ECE Timber Committee.

STRESSES FOR SOLID TIMBER

- 4-6-1 Paper 11 Derivation of Grade Stresses for Timber in UK - W T Curry
- 5-6-1 Standard Methods of Test for Determining some Physical and Mechanical Properties of Timber in Structural Sizes - W T Curry
- 5-6-2 The Description of Timber Strength Data - J R Tory
- 5-6-3 Stresses for EC1 and EC2 Stress Grades - J R Tory

- 6-6-1 Standard Methods of Test for the Determination of some Physical and Mechanical Properties of Timber in Structural Sizes (third draft) - W T Curry
- 7-6-1 Strength and Long-term Behaviour of Lumber and Glued-laminated Timber under Torsion Loads - K Möhler

TIMBER JOINTS AND FASTENERS

- 1-7-1 Paper 12 Mechanical fasteners and fastenings in timber structures - E G Stern
- 4-7-1 Paper 8 Proposal for a Basic Test Method for the Evaluation of Structural Timber Joints with Mechanical Fasteners and Connectors - RILEM, 3TT Committee
- 4-7-2 Paper 9 Test Methods for Wood Fasteners - K Möhler
- 5-7-1 Influence of Loading Procedure on Strength and Slip Behaviour in Testing Timber Joints - K Möhler
- 5-7-2 Recommendations for Testing Methods for Joints with Mechanical Fasteners and Connectors in Load-Bearing Timber Structures - RILEM 3TT Committee
- 5-7-3 CIB Recommendations for the Evaluation of Results of Tests on Joints with Mechanical Fasteners and Connectors used in Load-Bearing Timber Structures - J Kuipers
- 6-7-1 Recommendations for Testing Methods for Joints with Mechanical Fasteners and Connectors in Load-Bearing Timber Structures (seventh draft) - RILEM, 3TT Committee
- 6-7-2 Proposals for Testing Joints with Integral Nail Plates - K Möhler
- 6-7-3 Rules for Evaluation of Values of Strength and Deformation from Test Results - Mechanical Timber Joints - M Johansen, J Kuipers, B Norén
- 6-7-4 Comments to Rules for Testing Timber Joints and Derivation of Characteristic Values for Rigidity and Strength - B Norén
- 7-7-1 Testing of Integral Nail Plates as Timber Joints - K Möhler
- 7-7-2 Long Duration Tests on Timber Joints - J Kuipers
- 7-7-3 Tests with Mechanically Jointed Beams with a Varying Spacing of Fasteners - K Möhler
- 7-100-1 CIB Timber Code Chapter 5.3 Mechanical Fasteners; CIB Timber Standard 06 and 07 - H J Larsen

LOAD SHARING

- 3-8-1 Paper 8 Load Sharing - An Investigation on the State of Research and Development of Design Criteria - E Levin
- 4-8-1 Paper 12 A Review of Load Sharing in Theory and Practice - E Levin
- 4-8-2 Paper 13 Load Sharing - B Norén

DURATION OF LOAD

- 3-9-1 Paper 7 Definitions of Long Term Loading for the Code of Practice - B Norén
- 4-9-1 Paper 14 Long Term Loading of Trussed Rafters with Different Connection Systems - T Feldborg and M Johansen
- 5-9-1 Strength of a Wood Column in Combined Compression and Bending with Respect to Creep - B Källsner and B Norén
- 6-9-1 Long Term Loading for the Code of Practice (Part 2) - B Norén
- 6-9-2 Long Term Loading - K Möhler
- 6-9-3 Deflection of Trussed Rafters under Alternating Loading during a Year - T Feldborg and M Johansen
- 7-6-1 Strength and Long Term Behaviour of Lumber and Glued-Laminated Timber under Torsion Loads - K Möhler
- 7-9-1 Code Rules Concerning Strength and Loading Time - H J Larsen and E Theilgaan

TIMBER BEAMS

- 4-10-1 Paper 6 The Design of Simple Beams - H J Burgess
- 4-10-2 Paper 7 Calculation of Timber Beams Subjected to Bending and Normal Force - H J Larsen
- 5-10-1 The Design of Timber Beams - H J Larsen

ENVIRONMENTAL CONDITIONS

- 5-11-1 Climate Grading for the Code of Practice - B Norén
- 6-11-1 Climate Grading for the Code of Practice - B Norén

LAMINATED MEMBERS

- 6-12-1 Manufacture of Glued Timber Structures - J Kuipers
- 8-12-1 Testing of Big Glulam Timber Beams - H Kolb and P Frech
- 8-12-2 Instructions for the Reinforcement of Apertures in Glulam Beams -
H Kolb and P Frech
- 8-12-3 Glulam Standard Part 1: Glued Timber Structures; Requirements for Timber

FIBRE BUILDING BOARDS

- 7-13-1 Fibre Building Boards for CIB Timber Code - O Brynildsen

TRUSSED RAFTERS

- 4-9-1 Paper 14 Long Term Loading of Trussed Rafters with Different Connection
Systems - T Feldborg and M Johansen
- 6-9-3 Deflection of Trussed Rafters under Alternating Loading During a Year -
T Feldborg and M Johansen
- 7-2-1 Lateral Bracing of Timber Struts - J A Simon

CIB TIMBER CODE

- 2-100-1 Paper 2 A Framework for the Production of an International Code of
Practice for the Structural Use of Timber - W T Curry
- 5-100-1 Design of Solid Timber Columns - H J Larsen
- 5-100-2 A Draft Outline of a Code of Practice for Timber Structures - L G Booth

- 6-100-1 Comments on Document 5-100-1; Design of Timber Columns - H J Larsen
- 6-100-2 A CIB Timber Code - H J Larsen
- 7-100-1 CIB Timber Code Chapter 5.3 Mechanical Fasteners; CIB Timber Standard 06 and 07 - H J Larsen
- 8-100-1 CIB Timber Code: List of Contents (second draft) - H J Larsen

LOADING CODES

- 4-101-1 Paper 19 Loading Regulations - Nordic Committee for Building Regulations
- 4-101-2 Paper 20 Comments on the Loading Regulations - Nordic Committee for Building Regulations

STRUCTURAL DESIGN CODES

- 1-102-1 Paper 2 Survey of status of building codes, specifications etc, in USA - E G Stern
- 1-102-2 Paper 3 Australian codes for use of timber in structures - R H Leicester
- 1-102-3 Paper 4 Contemporary Concepts for Structural Timber Codes - R H Leicester
- 1-102-4 Paper 9 Revision of CP 112 - First draft, July 1972 - British Standards Institution
- 4-102-1 Paper 15 Comparison of Codes and Safety Requirements for Timber Structures in EEC Countries - Timber Research and Development Association
- 4-102-2 Paper 16 Nordic Proposals for Safety Code for Structures and Loading Code for Design of Structures - O A Brynildsen
- 4-102-3 Paper 17 Proposals for Safety Codes for Load-Carrying Structures - Nordic Committee for Building Regulations
- 4-102-4 Paper 18 Comments to Proposal for Safety Codes for Load-Carrying Structures - Nordic Committee for Building Regulations
- 4-102-5 Paper 21 Extract from Norwegian Standard NS 3470 "Timber Structures"
- 4-102-6 Paper 22 Draft for Revision of CP 112 "The Structural Use of Timber" - W T Curry
- 8-102-1 Polish Standard PN-73/B-3150: Timber Structures; Statistical Calculations and Designing
- 8-102-2 The Russian Timber Code: Summary of Contents

INTERNATIONAL STANDARDS ORGANISATION

- 3-103-1 Paper 2 Method for Preparation of Standards Concerning the Safety of Structures - published by International Standards Organisation (ISO/DIS 3250).
- 4-103-1 Paper 1 A Proposal for Undertaking the Preparation of an International Standard on Timber Structures - International Standards Organisation
- 5-103-1 Comments on the Report of the Consultation with Member Bodies concerning ISO/TS/P129 - Timber Structures - Dansk Ingeniorforening
- 7-103-1 ISO Technical Committees and Membership of ISO/TC 165
- 8-103-1 Draft Resolutions of ISO/TC 165

JOINT COMMITTEE ON STRUCTURAL SAFETY

- 3-104-1 Paper 1 International System of Unified Standard Codes of Practice for Structures - Published by Comité Européen du Béton (CEB)
- 7-104-1 Volume One: Common Unified Rules for Different Types of Construction Material - CEB

CIB PROGRAMME, POLICY AND MEETINGS

- 1-105-1 Paper 1 A note on international organisations active in the field of utilisation of timber - P Sonnemans
- 5-105-1 The Work and Objectives of CIB-W18 - Timber Structures - J G Sunley

INTERNATIONAL UNION OF FORESTRY RESEARCH ORGANISATIONS

- 7-106-1 Time and Moisture Effects - CIB W18/IUFRO S5.02-03 Working Party

INTERNATIONAL COUNCIL FOR BUILDING RESEARCH STUDIES AND DOCUMENTATION

WORKING COMMISSION W18 - TIMBER STRUCTURES

MEMBERSHIP OF CIB-W18

(November 1977)

Bruxelles

October 1977

INTERNATIONAL COUNCIL FOR BUILDING RESEARCH STUDIES AND DOCUMENTATION

13 MEMBERSHIP OF CIB-W18 TIMBER STRUCTURES

Co-ordinator & Chairman - J G Sunley

77-11-1

K Amonoo-Neizer	Building and Road Research Institute (Council for Scientific and Industrial Research) University PO Box 40 Kumasi Ghana	
Dr E Armbruster	Confédération Européene des Industries du Bois 1030 WIEN 3 Münzgasse 8 Austria	Tp 73 53 35 72 23 01
Dr B Bany	Centralny Ośrodek Badawczo-Projektowy Budownictwa Przemysłowego BISTYP 00-518 Warszawa UL Perkingowa 1 Poland	Tp 21 92 11 Tx 81 36 23
B Bohannan	Assistant Director for Wood Engineering Research USDA Forest Products Laboratory PO Box 5130 Madison Wisconsin 53705 United States of America	
Dr L G Booth	Department of Civil Engineering Imperial College of Science and Technology Imperial Institute Road London SW7 United Kingdom	Tp 01-589-5111 Ext 1308 Tx 261503
D H Brown	American Plywood Association 1119A Street Tacoma Washington 98401 United States of America	Tx 327430
P A V Bryant	Timber Research Unit CSIR PO Box 395 Pretoria Republic of South Africa	
O Brynildsen	Norsk Treteknisk Institutt Box 337 Blindern Oslo 3 Norway	

R Marsh
 Arup Associates
 Dean House
 7 Soho Square
 London W1V 6QB
 United Kingdom

Professor Dr K Mohler
 Universität Karlsruhe (TH)
 75 Karlsruhe 1
 Kaiserstrasse 12
 Postfach 6380
 Federal Republic of Germany
 Tp 6082211 and
 6082217

Professor L Montfort
 Institut National du Logement
 Boulevard St Lazare 10
 13-1030 Bruxelles
 Belgium
 Tp (02) 218 45 70

Dr B Noren
 Swedish Forest Products Research Laboratory
 Wood Technology Department
 PO Box 5604
 S-11486 Stockholm
 Sweden
 Tp 08 22 43 40
 Tx Woodres 10880

W Nozynski
 Centralny Osrodek Badawczo
 Rozwojowy Ppzemysku Stolarki Budowlaney
 05-200 Wokomin
 Laskowa 4
 Poland

A Pereira de Castro
 Institute de Pesquisas Tecnologicas
 de Salles Oliveira
 Caixa Postal 7141
 Sao Paulo
 Brazil

Dr R S Ratra
 National Building Organisation
 "G" Wing
 Norman Bhawah
 New Delhi - 110011
 India

P O Reece
 Hydro-Air International Limited
 London Road
 High Wycombe
 Buckinghamshire, HP11 1HR
 United Kingdom
 Tp 34006
 Tx 83450

U Saarelainen
 Technical Research Centre of Finland
 Timber Laboratory/PTA
 SF-02150 Espoo 15
 Finland
 Tp 90 4561
 Tx 122 972

W R Schriever
 Building Research Division
 National Research Council of Canada
 Ottawa 2
 Canada K1A 0R6

Professor P Sonnemans
 Sextant 37
 B-1080-Brussels
 Belgium

Professor E G Stern	Virginia Polytechnic Institute College of Architecture Blacksburg Virginia 24601 United States of America
J G Sunley (co-ordinator)	Timber Research and Development Association Hughenden Valley High Wycombe Buckinghamshire HP14 4ND United Kingdom Tp 0240-24-3091
Professor B Thunell	Swedish Forest Products Research Laboratory PO Box 5604 S-11486 Stockholm Sweden
J R Tory (Technical Secretary)	Princes Risborough Laboratory Princes Risborough, Buckinghamshire HP17 9PX United Kingdom Tp 084 44 3101 Tx 83559
F N Walsh	Council of Forest Industries of British Columbia 1500/1055 West Hastings Street Vancouver 1 Canada
T Williams	Hydro-Air SA (Pty) PO Box 48145 Blackheath Johannesburg 2001 South Africa Tp 678 5367/8 Tx 88371
Dr C R Wilson	Research and Development Department Council of Forest Industries of British Columbia 735 West 15th Street N Vancouver BC Canada V7M 1T2 Tp (604) 985-4191 Tx 2104507752
Proceedings only:	
R E Huberman	Human Education Research and Development Foundation 3671 SE Tenine Street Portland Oregon 97202 United States of America
Dr D R Yamai	Government Forest Experimental Station 5-Chome Shimo-Meguro Tokyo Japan
Mrs Marjorie Wickens (Librarian)	Eastern Forest Products Laboratory Canadian Forestry Service 800 Montreal Road Ottawa Ontario K1A 0W5 Canada Tp 613 993-9900 Tx 053 3606

Secretary-General CIB

Secretary General
International Council for Building Research Studies
and Documentation
Postbus 20704
Weena 704
Rotterdam
Holland

Tp 116181
Tx 22530

P R Colclough

Institute for Industrial Research and Standards
Ballymun Road
Dublin 9
Ireland

Tp 01 370101
Tx 5449

Mrs J C MacDonald
(serials librarian)

Nova Scotia Technical College
Halifax
Nova Scotia
Canada

Engineering Societies Library
345 East 47th Street
New York
NY 10017
United States of America

Tp 212 752 6800

INTERNATIONAL COUNCIL FOR BUILDING RESEARCH STUDIES AND DOCUMENTATION

WORKING COMMISSION W18 - TIMBER STRUCTURES

SAMPLING PLYWOOD AND THE EVALUATION OF TEST RESULTS

B Norén

Bruxelles

October 1977

TESTING OF STRUCTURAL PLYWOOD FOR ASSIGNING CHARACTERISTIC STRENGTH VALUES - (1) SAMPLING AND ASSISSING TEST RESULTS

B Norén - Swedish Forest Products Research Laboratory, Stockholm

1. Purpose
2. Definition of the population
3. Sampling of panels from the population
4. Sampling of test specimens
5. Definition of characteristic values
6. Derivation of characteristic values
7. Classification with respect to characteristic value

1 Purpose

The purpose of the testing is to establish characteristic values for strength (and stiffness) to be used in design and verification of safety of structures. It is essential in defining the population of plywood and in choosing sampling method that conditions in production, marking and end-use are considered.

2 Definition of the population

- 2.1 The population of plywood to which characteristic strength values are assigned shall be limited thus that the strength deviation at end-use is principally due to random variations. Hence, the population shall be unambiguously specified with respect to type (species) and grade (reference to a product standard), thickness and construction (lay-up) and - possibly - source (factory) and production time.
- 2.2 Integrating panels of different thickness and construction or from different sources into a mixed population is permitted either if it is proved that there is no significant deviation of characteristic strength values between the sub-groups or if the sub-groups are mixed in a random way when the plywood is used.

Plywood strength is sometimes expressed by a single veneer stress value to be applied on parallel plies. If the approximation of this model is accepted at different constructions (thicknesses), a population of mixed constructions could be considered in assigning characteristic strength values for design and possibly in sampling for continuous quality control testing. For the kind of testing, here dealt with, plywood of different constructions (thicknesses) should, however, as a rule be considered as belonging to different populations.

Sometimes the product standard (in particular the specifications for grading the veneers) do not guarantee that the plywood produced at different factories will have the same strength, for example due to different timber sources. In such cases the population may have to be specified with respect to source.

- 2.3 The period during which the plywood referred to as a population is produced should be as long as possible without involving such changes in the production which can be expected to have a significant influence on the properties to be established by the testing.
- 2.4 A population consisting of plywood from several factories may be substituted by plywood from a limited number of factories, if it is proved beyond doubt that this will not increase the estimated characteristic strength. On similar conditions a population consisting of plywood of several constructions (thicknesses) may be substituted by a population consisting of a limited number of selected constructions.

If one characteristic strength value shall be evaluated for a plywood of standard type, construction and thickness, made at for example 150 factories, one may find out from a limited number of testing (compared with what is stipulated in p. 3.1), either that the population must be divided into a number of populations, c.f. 2.1, or - if the difference between factories is comparatively small - that the strength values can be evaluated from a number of those factories that are at the lower end with respect to the strength of their produced plywood.

3 Sampling of panels

- 3.1 The number of panels in a sample, drawn for testing from a population or substitute population, defined in p. 2, must allow each strength property to be tested on specimens from at least $N = 30$ panels of each construction (thickness) and thereby from at least $n = 5$ panels from each factory (production time).
- 3.2 Samples shall be drawn at random over the production time defined for the population (p. 2.3). When the number of panels from one factory (production line) for testing one specific strength property is n , these panels must be drawn from n different batches (preferably have been produced by n different shifts).

4 Sampling of specimens from panels

- 4.1 A specific schedule shall be used for the cutting of test specimens from panels. This schedule shall define the distance between the specimens and, as a rule, their position relative to the edges of the panel. If a characteristic feature of the panels (such as a joint) occurs on a regular distance from the edges of the panels, the position of the cutting schedule relatively to the edges shall be changed at random from panel to panel.
- 4.2 When the size of the cutting schedule is larger than the panel, the schedule may be applied on two or more adjacent panels in the batch.

The number of specimens and cutting schedules are generally given in testing standards. (For structural plywood see ISO/TC 165 N, document 14E.)

5 Definition of characteristic value

- 5.1 For characteristic values of strength or moduli of elasticity (rigidity etc.) are used the 1-, 5-, 10- and 50-percentiles. As a rule the 5-percentile should be used for the strength and moduli of elasticity for calculating strength (verification of limit state of failure), while the 50-percentile

(mean value at normal distribution) should be used for calculation of deformation at the serviceability limit state.

The choice of percentile is dependent on the base used in calibrating the (partial) safety factors. If the standard deviation and type of distribution is known one characteristic value can be calculated from another.

6 Derivation of characteristic value

6.1 When characteristic strength values are estimated for a population of plywood panels (p. 2) from test results from samples of limited numbers (p. 3) the unreliability of the results should be duly considered. This is achieved by applying an increased confidence.

With "increased confidence" is here meant that the method of estimation should imply a probability higher than 0.5 that the estimated characteristic value is lower than the real value.

6.2 The characteristic value may be estimated as

$$m_k = \bar{m} \exp\left(-k \frac{s}{\bar{m}}\right) \quad (6:1)$$

and if $k \frac{s}{\bar{m}} \leq 0.25$ as

$$m_k = \bar{m} - ks \quad (6:2)$$

In (6:1) and (6:2) m_k denotes the characteristic value estimated for the population, \bar{m} is the mean value and s the standard deviation for the sample. The value of the coefficient k depends on the demand of probability that m_k is not overestimating the characteristic value of the population, on the percentile used to define this characteristic value and on the number of individual values (N) on which \bar{m} and s are based.

If the real characteristic value of the population is M_k we may want 75% confidence that the value m_k calculated from a sample by (6:2) is lower than M_k . In the case the individual strength values are normally

distributed and M_k is defined by the 5-percentile, the values given in table 6.1 may be used for k in (6:2).

Table 6.1 Value of k in (6:2) for estimating characteristic strength (5-percentile) from N strength values in a sample¹⁾

$N =$	15	20	<u>30</u>	40	100
$k =$	1.99	1.93	1.87	1.83	1.75

7 Classification with respect to characteristic value

A population (p. 2) can be considered in grade if a value, calculated from test results from a sample of limited number of panels (p. 3) is at least equal to the demand characteristic grade-value m_k :

$$\bar{m} \exp\left(-k \frac{s}{m}\right) \geq m_k \quad (7:1)$$

$$\text{or if } k \frac{s}{m} \leq 0.25$$

$$\bar{m} - ks \geq m_k \quad (7:2)$$

(Denotations see p. 6.2)

The value of k depends on the demanded confidence of the classification, on the definition of the characteristic value (what percentile) and on the number of panels tested in the sample.

If it is demanded that the probability should be 0.75 that a population with a real characteristic value $M_k = m_k$ is rejected as being below grade, the k -values from table 6.1 can be used, provided the distribution of individual strength values is normal and the characteristic value is defined by the 5-percentile.

1) Determination of load-bearing capacity by testing. The National Swedish Board of Physical Planning and Building, Approval Rules No. 1975:4.

However, the demand may alternatively be expressed by the probability that a population with a characteristic strength $M_k = m_k - C s_p$, less than the grade-value (m_k) is estimated as within the grade. As an example ¹⁾ is assumed $C = 0.25$, normal distribution of individual strength values, standard deviation of the population equal to that of the sample ($s_p = s$). It is further suggested that it is allowed 15.9 % probability of acceptance to the grade of a population with a 5-percentile 0.25 times the standard deviation lower than the grade value. The value of k is then calculated from

$$k = \frac{1}{\sqrt{n}} + (1.645 - 0.25) \quad (7:3)$$

These k -values are lower than them given in table 6.1 for estimating the 5-percentile of the population, the reason partly being the assumption $s_p = s$. If instead the coefficient of variation is known ($V_p = V = s/\bar{m}$), the k -value is **changed** according to table 7.1.

And if s_p as well as V_p are unknown, the k -value to be used in (7:2) can be determined from the non-central t -distribution, see table 7.1, last line.

Table 7.1 Value of k in (7:2) for assigning to grade ¹⁾

N =	15	20	30	40	100
V_p known	1.66	1.62	1.58	1.55	1.50
V_p and s_p unknown	1.88	1.80	1.71	1.66	1.54

1) Safety Codes for Load-carrying Structures. Nordic Committee for Building Regulations (NKB). Proposal September 1977.

TESTING OF STRUCTURAL PLYWOOD FOR QUALITY CONTROL

B Norén

Swedish Forest Products Research Laboratory

A:0 General

There are several methods to check whether a product is continuously produced to certain demands. There are direct methods of product control, such as testing strength properties of plywood on samples of panels regularly drawn from the production. There are indirect methods, such as checking the production means or checking a substitute for the property (visual grading, non destructive testing) or a substitute for the product (veneer testing instead of plywood testing).

In manufacturing of plywood, the quality control is generally a combination of indirect and direct methods. By the indirect methods it is possible to predict with some confidence the strength properties of the plywood. Thereby the number of panels destroyed by testing is reduced. Actually, continuous strength testing of structural plywood is not applied in quality control in many countries. Such testing, carried out for some period may, however, be valuable for following up assigned characteristic strength values.

A:1 Purpose

Testing samples from the production line or the stock is a way of verifying that the products satisfy certain demands. The test results should primarily guide the manufacturer with respect to measures to be taken concerning the production. By following the mean values and the standard deviations of the samples, he can separate chance causes of variation which are natural for the production from assignable causes which he can change.

In addition, there may be an external official demand, such as for a minimum 5-percentile of strength. Usually, this demand is also verified primarily through the manufacturers own testing of samples. Possible official spot-checking by testing once or twice a year can contribute very little to the statistical treatment and is mainly used to calibrate the factory testing.

A:2 Sampling

Samples for testing must be distributed with respect to such controlled changes in the production which are likely to affect the property to be checked. It is a matter of defining "sub-populations" or batches within which the variation of the tested property is principally random.

The number of test specimens (plywood panels) to be tested during a period is often made dependent on the number of produced units. Here is, as an example, given the number of joints to be tested from each production batch at routine quality control of finger-jointed structural timber. 1)

Number of joints in production batch	Minimum number of joints to be tested
1000 or less	3
1001 - 2000	4
2001 or more	5

Specimens should be drawn at random over the period the batch is produced. Although in many kinds of production the number of units in a batch will be less than 1,000 there will be several such batches produced to give a sufficient number of test results for estimating the statistical parameters within a reasonable short time.

A:3 Characteristic strength value

To verify from the quality control testing that the product has a characteristic strength at least equal to a specified value, the method previously shown can be used (7. Classification with respect to characteristic value.) The systematic (assignable) variations found from the control charts must of course be excluded. The results from similar batches can be pooled and after some time the number of results is increased to allow a low k-factor to be applied. Furthermore, a mean value of the standard deviation may be used instead of the deviation of the sample.

1) ECE-TIM/WP. 3/AC. 3/8 Annex II 24 June 1977

INTERNATIONAL COUNCIL FOR BUILDING RESEARCH STUDIES AND DOCUMENTATION

WORKING COMMISSION W18 - TIMBER STRUCTURES

Testing of Big Glulam Timber Beams

by

H Kolb and P Frech

Otto-Graf-Institut Stuttgart

Bruxelles

October 1977

Lehrstuhl für
Ingenieurholzbau u. Baukonstruktionen
Universität (TH) Karlsruhe
Prof. Dr.-Ing. K. Möhler

Introduction

For a long time it has been known that the bending strength of timber depends on its dimensions, especially on its cross-sectional depth.

In 1924 Newlin and Traver first showed this dependence by tests and theoretical deduction and determined for cross sectional depths up to 12 inches (about 300 mm) a reduction factor dependent on the depth H

$$k = 1,07 - 0,7 \sqrt{\frac{H}{2}}$$

With the development of glulam structures it was possible to produce beams with depths exceeding 300 mm and it became necessary to modify or reestablish the formula.

Dawley and Youngquist indicated in 1947 a reduction factor k according to this formula:

$$k = 0,625 \frac{(H^2 + 143)}{(H^2 + 88)}$$

With an increasing beam depth H the reduction according to this formula became bigger than for the formula of Newlin and Traver.

A board with a 2 in. depth (about 50 mm) was used as "reference beam".

As in the American calculation instructions most of the calculated stresses with regard to a sufficient rupture strength apply to a cross-sectional depth of 12 in. (300 mm), this formula is:

$$k = 0,81 \frac{(H^2 + 143)}{(H^2 + 88)}$$

In the above quoted formulae the depth H is in inches.

In fig. 3 the American and Soviet reduction factors k are represented and compared to the mean value curve calculated by us, presuming a safety against rupture of $\eta = 3,0$.

In general it can be said that for deeper beams the allowable bending stress has to be reduced with a factor which corresponds to the relation between the allowable tensile stress and the allowable bending stress.

As long as in Germany no reduction of the allowable bending stress is demanded for beam depths $h > 500$ mm, it is necessary to have a very careful choice and grading of timber with, if possible, laminae of quality I.

As an alternative to the introduction of reduction factors one has to think it over if the requirements to the existing quality classes concerning the gross density and the annual layers width shouldn't be increased.

A further natural requirement is a good execution of finger jointing in all boards of the beam.

Table 1

bending test of the beams, maximum loads and calculated stresses

type of beam	span m	depth mm	rupture load max P kN	calculated bending stress max σ_B N/mm ²	calculated shear stress max τ N/mm ²	E-module E N/mm ²
I	30,00	2000	1136,0	32,0	2,13	11860
II	30,00	2000	1024,0	28,8	1,92	12770
I A	13,50	900	368,0	23,0	1,53	11540
I B	13,50	900	352,0	22,0	1,47	11340
I C	6,00	400	271,2	38,1	2,54	11120
I D	5,25	350	239,4	38,5	2,56	11100
I E	3,00	200	172,4	48,5	3,23	11500
II A	9,00	600	281,6	26,4	1,76	11580
II B	7,50	500	342,3	38,5	2,57	11030
II C	6,75	450	270,0	33,8	2,25	11780
II D	6,60	440	301,2	38,5	2,57	10960
II E	6,45	436	240,8	31,5	2,10	11710
II F	6,00	400	198,0	27,8	1,86	10110
II G	6,00	400	270,0	38,0	2,53	10590
II H	5,50	365	226,0	35,0	2,32	11160
II J	5,50	365	243,2	37,7	2,50	11740
II K	4,50	300	282,6	53,0	3,53	11730
II L	3,75	250	155,6	35,0	2,33	11520
II M	3,75	250	140,0	31,5	2,10	10640
II N	3,00	200	211,5	59,5	3,97	12230
II O	3,00	200	171,2	48,2	3,21	11600
II P	3,00	200	174,2	49,0	3,27	12120

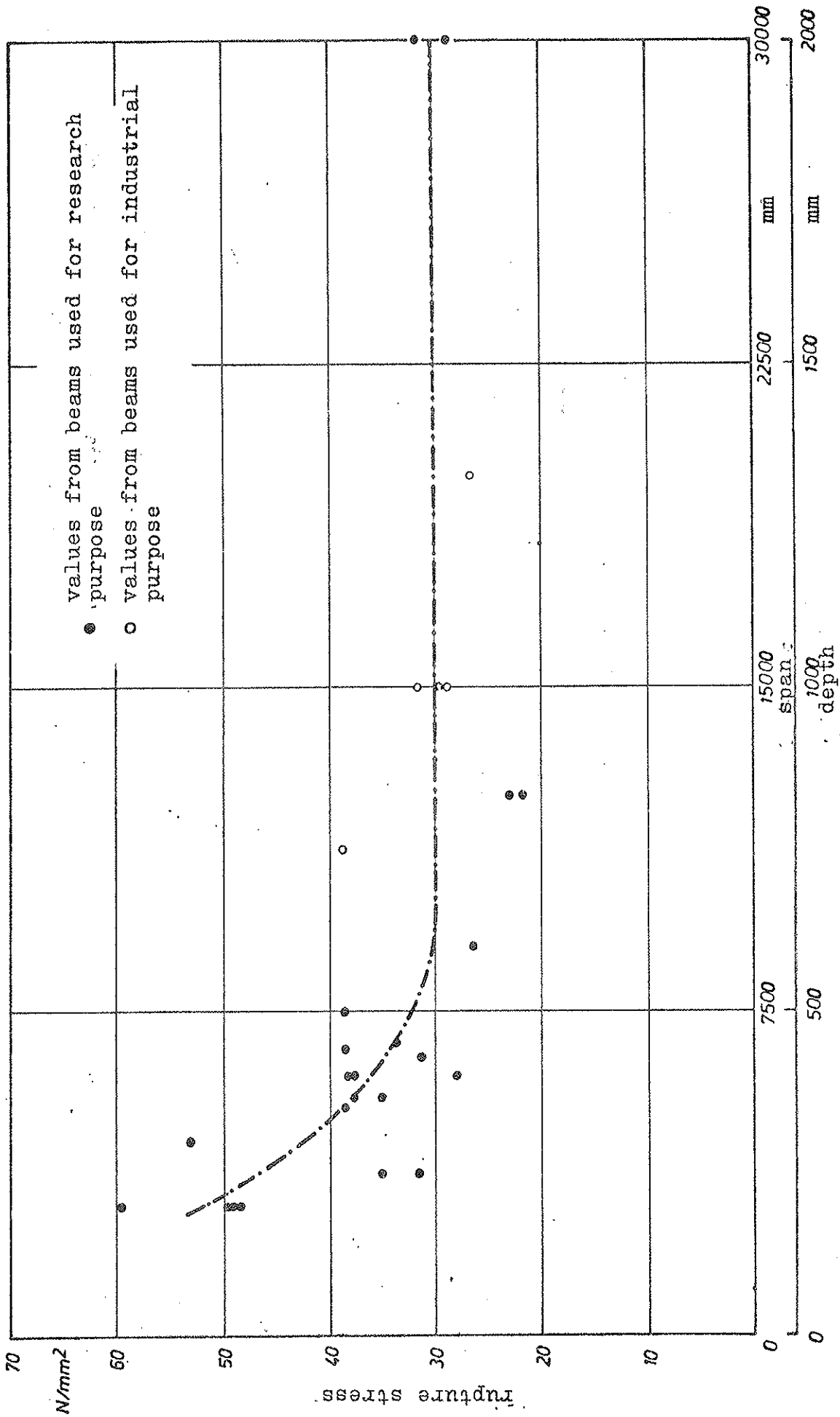

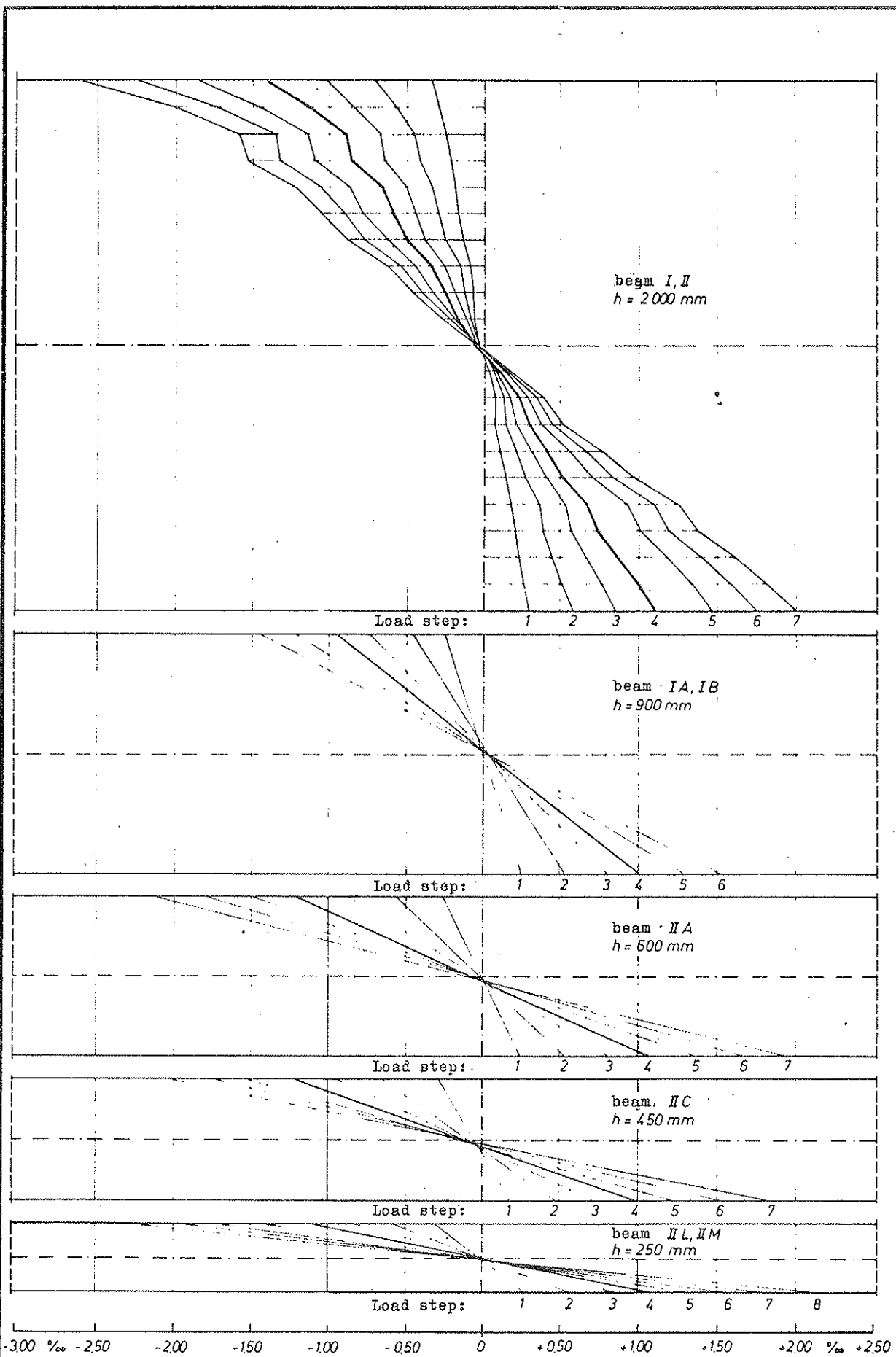

Fig. 2 Longitudinal stresses at different beam depths

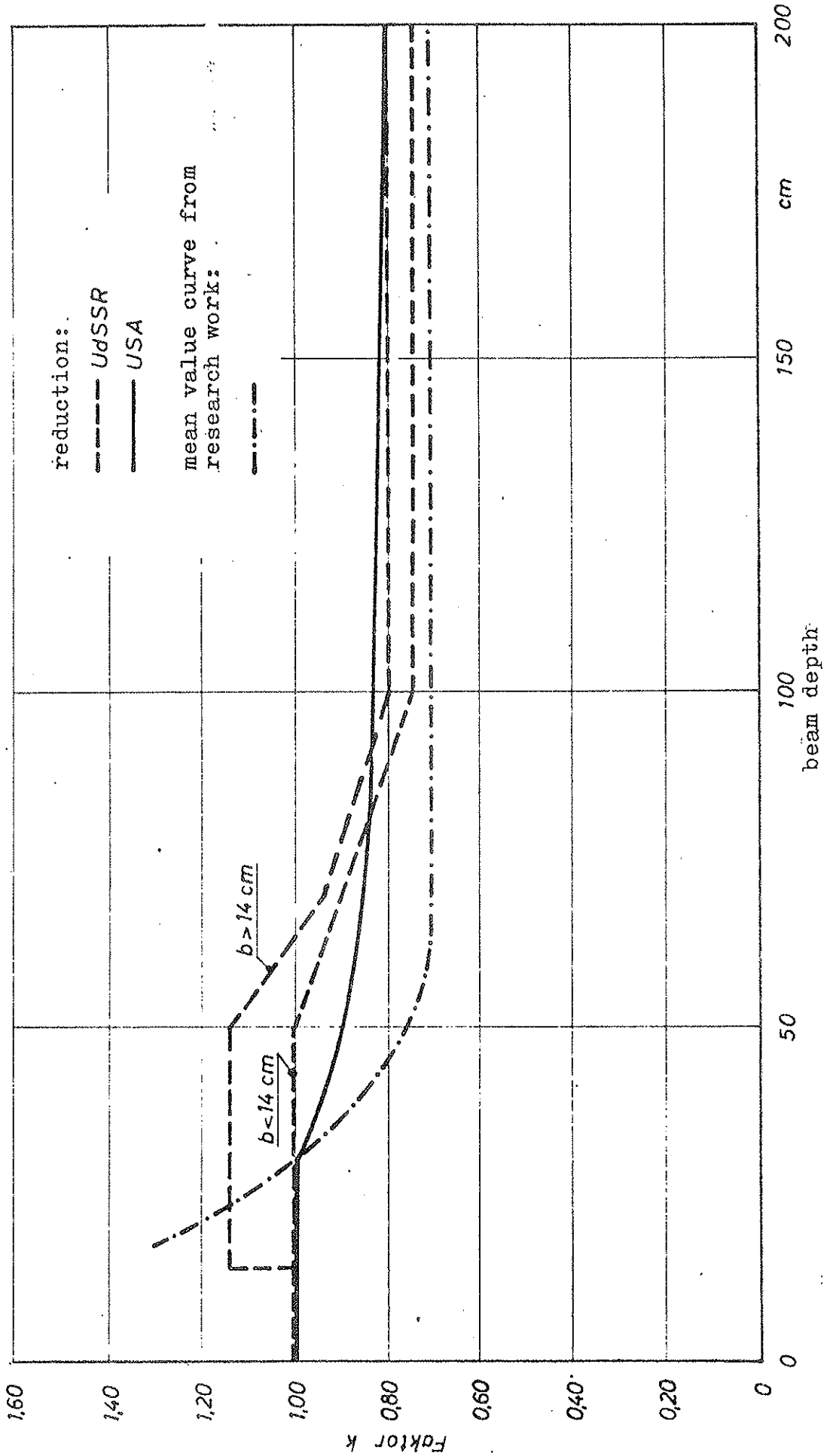

Fig. 3 American and Soviet reduction factors k and mean value curve from research work based on a threefold safety against rupture

INTERNATIONAL COUNCIL FOR BUILDING RESEARCH STUDIES AND DOCUMENTATION

WORKING COMMISSION W18 - TIMBER STRUCTURES

Instruction for the Reinforcement of
Apertures in Glulam Beams

by

H Kolb and P Frech

Otto-Graf-Institut Stuttgart

Bruxelles

October 1977

Instructions for the reinforcement of apertures in
glulam beams

(Recommendation on the basis of tests carried out by
FMFA Stuttgart)

Reinforcing must be done by beech plywood slabs AW 100 according to DIN 68705, sheet 3.

The total reinforcing thickness d (per side $d/2$) is determined according to the shear stress τ in the middle of the aperture and the beam width B .

shear stress τ		total thickness d of the reinforcement as a function of the beam width B
N/mm^2	(kp/cm^2)	%
0	(0)	10
0,4	(4)	35
0,8	(8)	50
1,2	(12)	65

Intermediate values must be interpolated linearly.

Slab thickness ≥ 10 mm

Size of the apertures and reinforcements

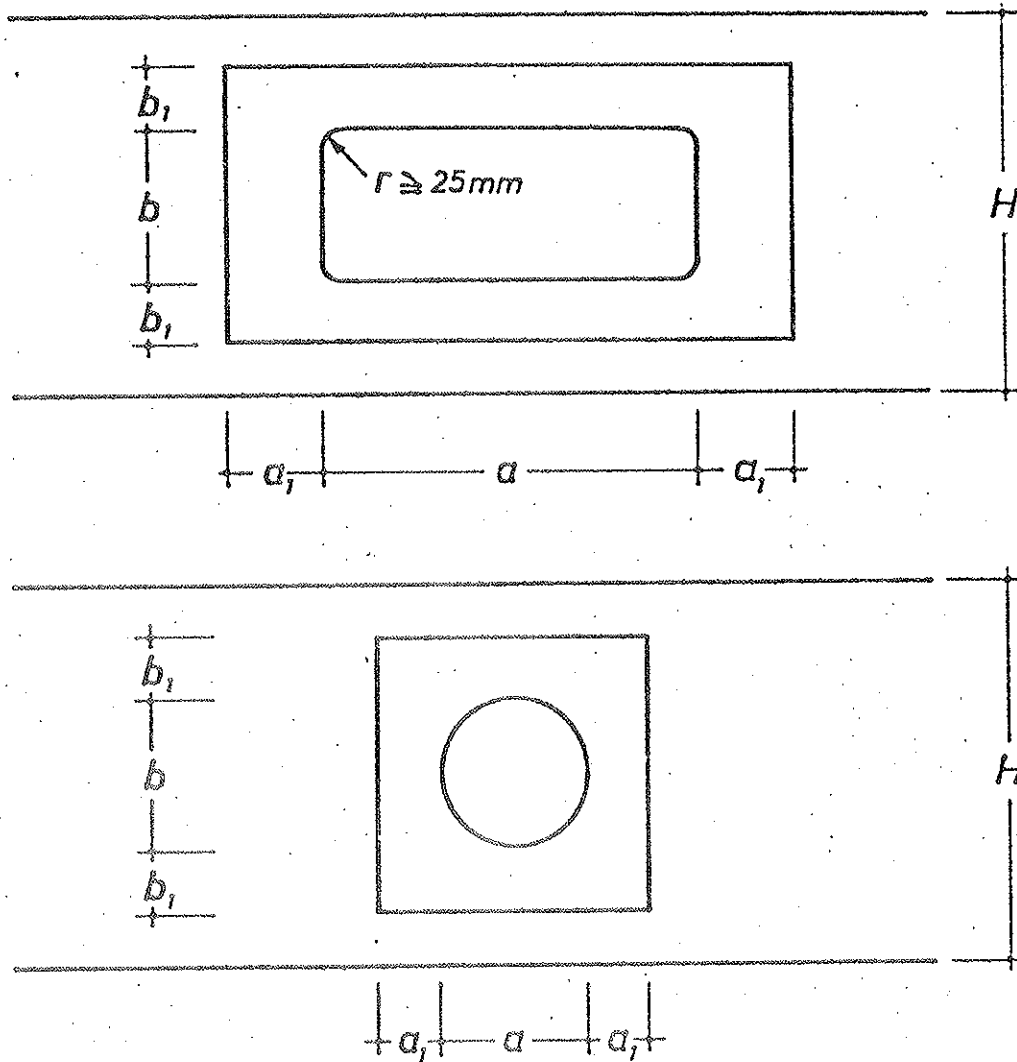

$$a \leq H$$

$$b \leq 0,4H$$

$$a_1 \geq 0,25a \geq b_1$$

$$b_1 \geq 0,4b \geq 0,1H$$

Grain direction of the face veneer parallel to the grain direction of the beam

Gluing with resorcinol glue,
pressure about $0,6 \text{ N/mm}^2$ (6 kp/cm^2)

The corners have to be rounded with a rayon of at least 25 mm. Normally the apertures should be symmetrical to the longitudinal axis of the beam. But at least a distance of $0,3 H$ to the above or below border has to be observed.

In the region of the aperture and the reinforced zones no important single loads ought to be introduced into the beams. If ducts with media the temperature of which doesn't correspond to the room temperature are directed through the apertures, the ducts have to be carefully insulated. Cross-cut ends should be protected by appropriate coatings against uncontrolled penetration of moisture.

If no appropriate press equipment is available for the gluing of the reinforcing slabs, they can be mounted by nail gluing according to DIN 1052, chapt. 11.5.9. The holes in the veneer slabs have to be rough-drilled with 85 % of the nail diameter.

It is necessary that during gluing the moisture content of the slabs corresponds to the expected compensating moisture.

Apertures are openings where at a shear stress $\tau = 1,2 \text{ N/mm}^2$ a or $b \geq 0,05 H$ and at a shear stress $\tau = 0 \text{ N/mm}^2$ a or $b \geq 0,10 H$. Between these values one has to interpolate linearly.

This instruction applies only to glulam beams which are mounted under the roof, thus not exposed to weather from one or all sides, see also DIN 1052, sheet 1, 3.2.1.

INTERNATIONAL COUNCIL FOR BUILDING RESEARCH STUDIES AND DOCUMENTATION

WORKING COMMISSION W18 - TIMBER STRUCTURES

GLULAM STANDARD PART 1

GLUED TIMBER STRUCTURES; REQUIREMENTS FOR TIMBER

(Second Draft)

Bruxelles

October 1977

2nd Draft

revised and taken as a resolution during the session
in Vienna on 11.5.1977

GLUED TIMBER STRUCTURES
REQUIREMENTS FOR TIMBER

Part 1

Preface:

This GLULAM-STANDARD should give the base for determinations relating to timber, rating and performance of glued timber structures in the member countries of GLULAM. Furthermore this standard should be the base for the intended CEN- and ISO- standards in the field of glued timber structures.

There are two parts of the GLULAM-STANDARD:

Part 1: GLUED TIMBER STRUCTURES
 REQUIREMENTS FOR TIMBER

Part 2: GLUED TIMBER STRUCTURES
 RATING AND PERFORMANCE
 (will be prepared)

1. Scope:

This draft of the GLULAM-STANDARD Part 1 applies to laminated or to cross-laminated load bearing structural elements made of sawn timber from coniferous species. Indicated dimensions refer to the planed condition unless they do not explicitly refer to the raw (unplaned) condition.

3. Definitions:

2.1 Laminated Timber:

Laminated timber consists of boards glued together, the grain directions of all the boards being essentially parallel. Fig.1.

2.2 Cross Laminated Timber:

Cross laminated timber consists of boards glued together, the grain directions of neighbouring boards being not parallel. Fig. 2.

2.3 Knot Area Ratio (KAR) :

The knot area ratio is the summary of the projected cross-sectional areas of all knots within a predetermined reference length parallel to the grain of the wood and within an area, where a maximum may be expected, divided by the total cross-sectional area of the lamella. Reference length see section 5.4.

2.4 Moisture Content:

Weight of water within the wood, expressed as percentage of the weight of oven-dry wood.

2.5 Checking:

Shrinkage checks and heart checks: Separations usually across the growth rings as a consequence of stresses due to shrinkage of the wood.

Ring shake: Separations following the grain, between the individual growth rings.

Splits: Checks following the grain, forming cracks extending either partially or thoroughly across the board.

2.6 Slope of Grain:

The angle between the directions of the grain and the axis of the wooden piece, measured over an agreed distance.

2.7 Wane:

Local deviations of the cross-section of the board from its clear rectangular shape due to the original shape of the roundwood.

2.8 Spiral Grain:

Spiral grain is given, if the fibres of the wood wind spirally around the axis of the log.

3. Methods of Measurement and Dtermination:

3.1 Knot Area Ratio (KAR):

The maximum knot area ratio of each lamella shall be determined. Knots with a diameter of up to 5 mm may be ignored. All other knots and knotholes, irrespective of their shape and location, shall be included in the determination of KAR, by projecting them rectangularly into the plane of the board.

Determining the projected area, overlappings of the projected knots are neglected. Fig. 3.

3.2 Slope of Grain:

The slope of grain shall be measured over a reference length of

500 mm.

4. Moisture Content:

The moisture content shall be measured by means of proven, suitable and calibrated instruments.

Explanatory Note:

Measurements must be made prior to gluing, after the timber had been seasoned to the required moisture content and brought to the necessary dimensions.

5. Quality Requirements:

5.1 Grades:

Sawn timber from coniferous species of European origin for laminated or cross-laminated glued load bearing timber structures are classified into two categories, namely

- Grade 1 (Structural Timber)
- Grade 2 (Normal Building Timber).

Unless it is not commented in the following requirement specifications which grade they refer to, they have to be applied to both of them.

Sawn timber from coniferous species of other origin may be used, provided it meets the requirements of this standard.

5.2 Moisture Content:

At the time of gluing the timber shall have a moisture content corresponding to the average moisture content which may be expected to have it as a rule under service conditions, whereas the moisture content must not decrease below a minimum of as much as 7% nor in any case exceed a maximum of as much as 17%.

Therefore, as a rule, the moisture content shall be at the time of gluing:

With service in closed, heated rooms

$$9 \pm 2\%$$

With service in closed, unheated rooms or in open, roofed humidity

$$12 \pm 2\%$$

With service in open air or in rooms with exceedingly high humidity

$$15 \pm 2\%$$

The difference of the moisture contents among the individual lamellas must not be more than 4%.

5.3 Raw Density, Growth Ring Width:

There is no need to determine the raw density of the timber in particular. For the wood species mentioned under point 5.1 it may be assumed to be above 0.4 in air dry condition (wood moisture content of 20%).

The requirements are deemed to be met, if the average width of the growth rings is as much as

- for Grade 1 : 5 mm maximum
- for Grade 2 : 6.5 mm maximum.

Wider growth rings are permissible, if the raw density is as much as 0.4 g/cm^3 .

Particular attention is to paid to extremely narrow-ringed, light- weighted timber.

5.4 Knot Area Ratio:

The knot area ratio shall not exceed within a reference length of 300 mm:

- 0.30 for Grade 1
- 0.50 for Grade 2.

5.5 Size of Spike Knots:

In addition to paragraph 5.4, the width of spike knots, measured at the surface of the timber as shown in Fig.4, shall not exceed:

- 25 mm for Grade 1
- 40 mm for Grade 2.

5.6 Slope of Grain:

As a rule within a reference length of 500 mm, the slope of grain shall not exceed:

Grade 1 : 35 mm = 7%	1 : 14, locally up to 10%
Grade 2 : 60 mm = 12%	1 : 8, locally up to 20%.

5.7 Pith:

Pith streaks and timber cut through the pith are permissible, provided the pith is not spongy.

5.8 Checks:

Checks are permissible with boards intended for horizontal laminated or cross-laminated structural members, provided the angle between check and surface of the board is at least 45° , Fig. 5.

However, only very small heart checks and medium sized checks due to shrinkage are permitted for boards intended for vertically glued load bearing structural members, irrespective of the magnitude of the angle referred to above.

5.9 Wane:

Wane is permissible for lamellae, provided they do not show on glued structural members in planed condition.

5.10 Resin:

Parts, being resinous over their entire surface or showing resin pockets scattered over their surface are not permissible. Smaller resin pockets may be permitted to a low extent.

5.11 Other Defects:

Not permissible are:

Spiral grain (except for a low extent)

Mechanical damages

Insect ducts (permissible to a low extent, but they must not show on the finished member).

R o t

Discolourations (except blue stain)

Further on, all flaws causeing a considerable loss of strength or having an adverse effect on gluing.

5.12 Dimensions:

5.121 Thickness:

Generally the thickness of the lamella after planing shall not exceed:

33 mm.

Under particular circumstances, as straight beams and/or interior use, and under favourable conditions, the thickness of the lamella may range up to:

45 mm .

With curved structural members the thickness of the lamellae shall be determined according to GLULAM-STANDARD, Part. 2.

5.122 Width:

The width of the lamella shall not exceed 210 mm, provided no special precautions are taken. The total cross-sectional area of the individual lamella shall not exceed 70 cm².

6. References to Other Standards:

GLULAM- STANDARD Part 2.

GLUED TIMBER STRUCTURES
RATING AND PERFORMANCE

(will be prepared)

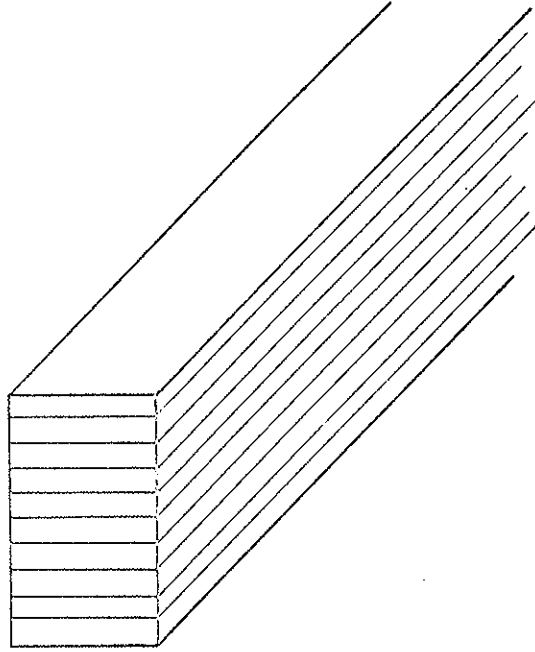

Fig. 1

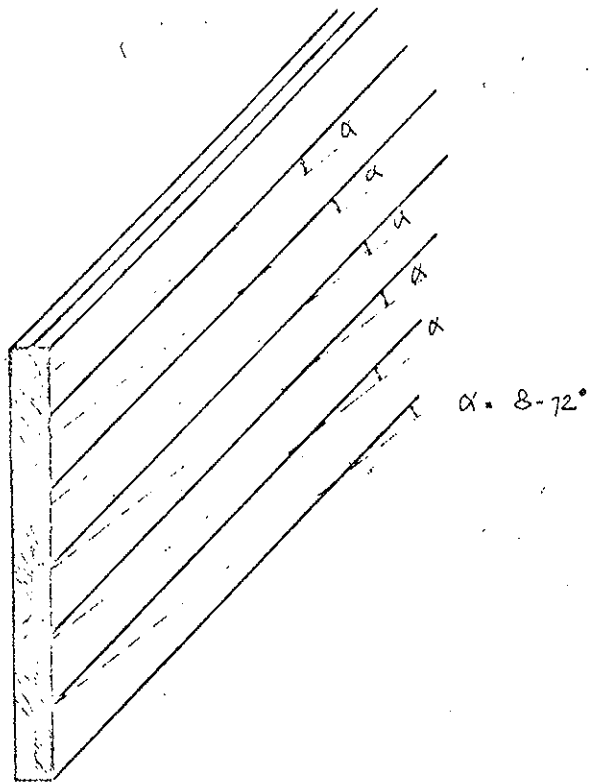
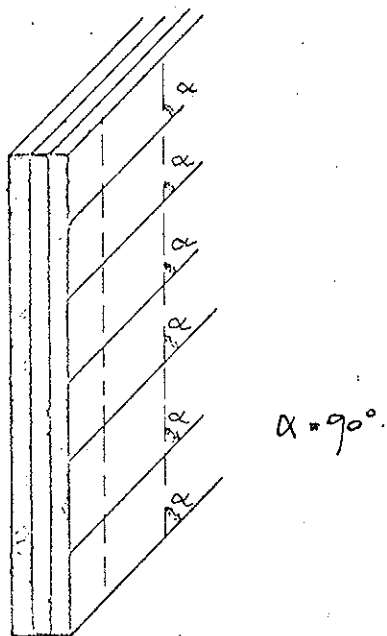
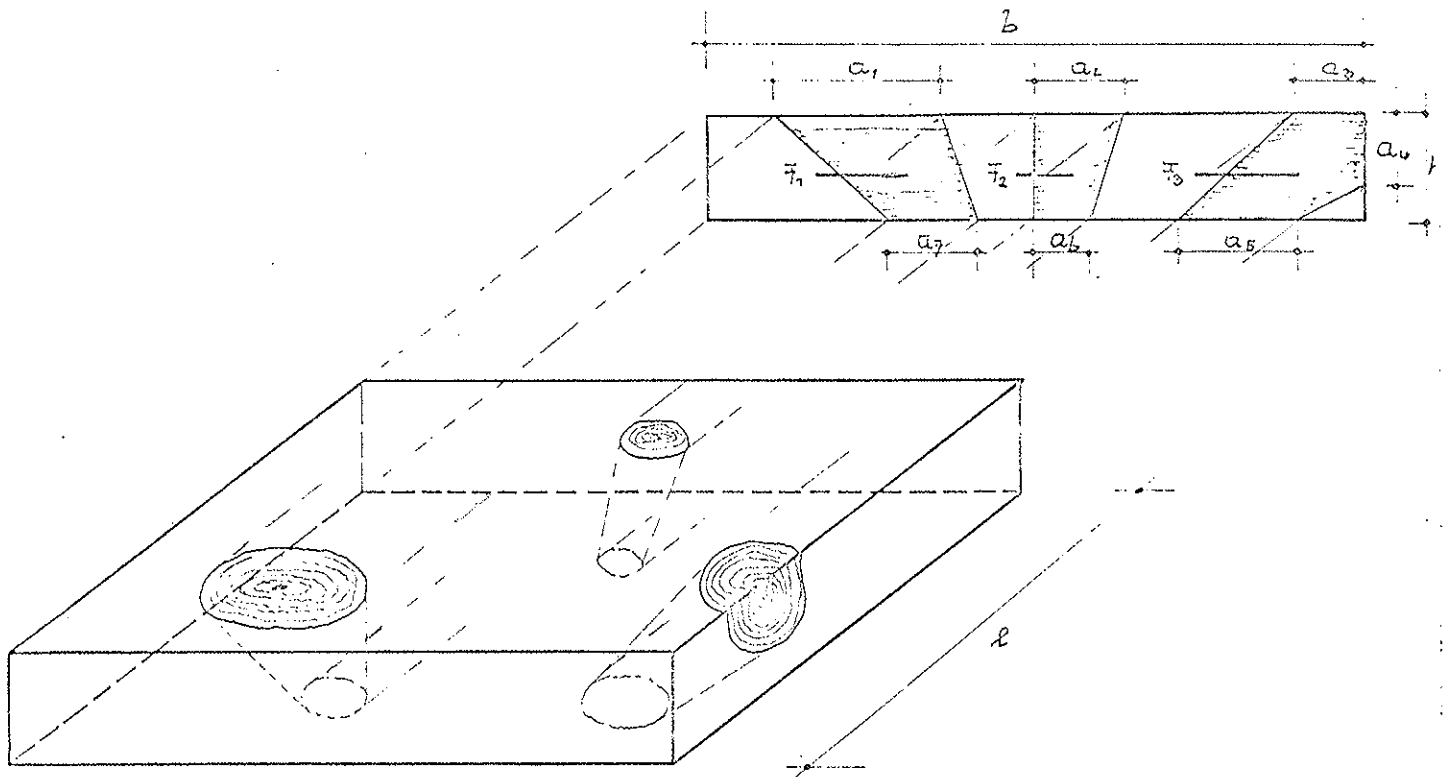

Fig. 2





$$KAR = \frac{F_1 + F_2 + F_3}{b \times h}$$

Fig. 3

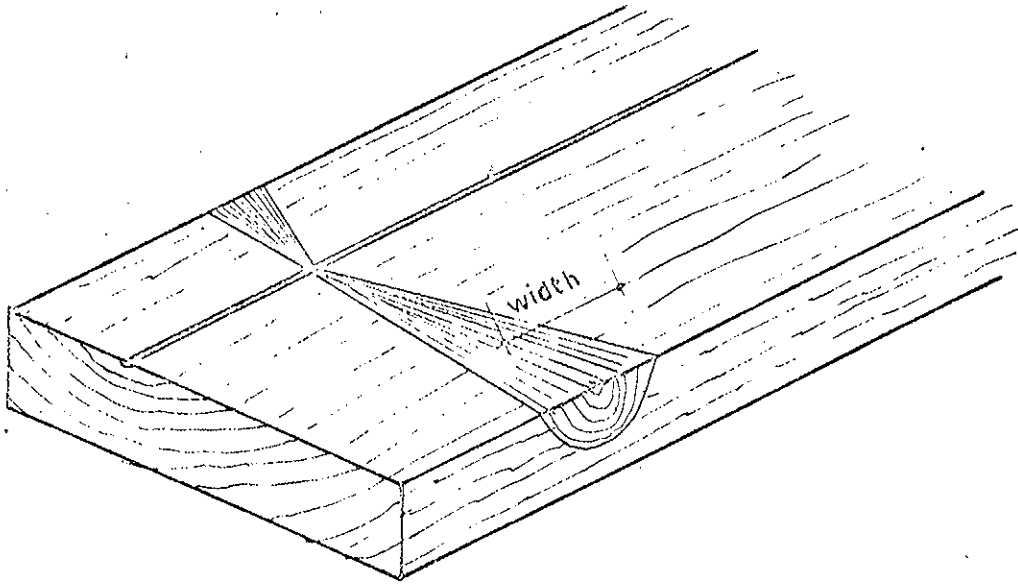

Fig. 4

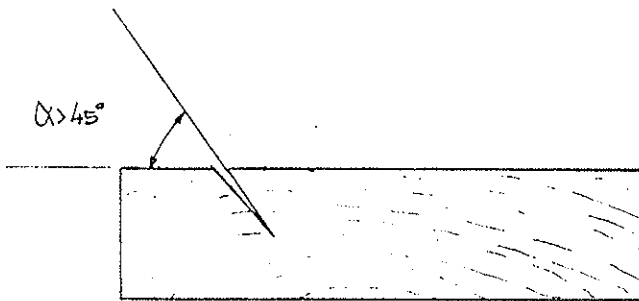

Fig. 5

INTERNATIONAL COUNCIL FOR BUILDING RESEARCH STUDIES
AND DOCUMENTATION

WORKING COMMISSION W18 - TIMBER STRUCTURES

LATERALLY LOADED TIMBER COLUMNS

TESTS AND THEORY



H J Larsen

Instituttet for Bygningsteknik, Aalborg

Denmark

MEETING EIGHT

Bruxelles, Belgium

October 1977

Lehrstuhl für
Ingenieurholzbau u. Baukonstruktionen
Universität (TH) Karlsruhe
Prof. Dr.-Ing. K. Möhler

1. INTRODUCTION

In the classical theory of centrally loaded columns and lateral buckling of beams it is assumed that the materials are ideal-elastic and that the members are straight up to a certain critical load by which the rupture occurs by sudden deflection of the structure. The rupture is thus considered a stability phenomena only.

The correspondence between theory and practice is good for slender structures, but for non-slender structures there are great deviations which are traditionally explained by a stress dependent modulus of elasticity.

For timber, at least, there is bad correspondence between the moduli of elasticity normally measured and those that must be assumed theoretically to explain the load-carrying capacities for columns that are found by tests. For columns the correspondence between theory and tests has proved much better if the columns are assumed to be elastic to rupture but with deviations from straightness.

In the present paper this view has been extended to comprise lateral buckling of beams with axial force under the assumption of pre-curvature in two directions and pre-torsion.

The theoretical load-carrying capacities have been derived in section 2. The expressions have been verified by tests described in section 3.

In section 4 the load-carrying capacity expressions found are discussed and simple, approximated design expressions are set up.

2. THEORY

2.1 The differential equations

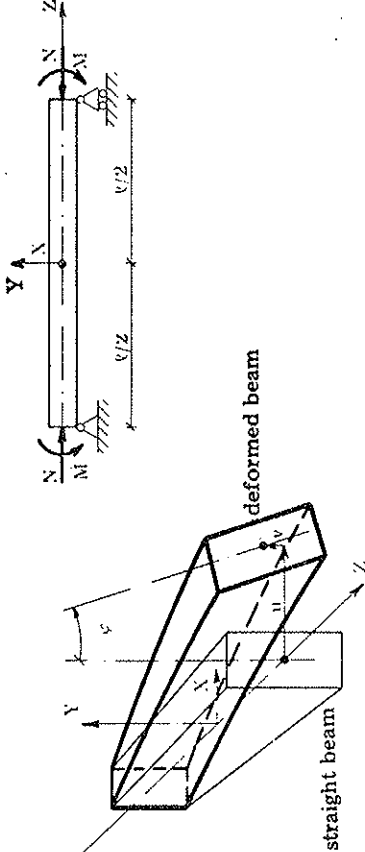

Figure 2.1

A straight beam with the length l and constant cross-section is considered. The cross-section with the area A is shown in the figure as a rectangle. For other sections X and Y are the main axes. The bending stiffness about the axes is EI_x and EI_y , while the torsional rigidity is GI_φ . E is the modulus of elasticity, G the shear modulus, I_x the moment of inertia about the X -axis, I_y the moment of inertia about the Y -axis and I_φ the moment of inertia in torsion. The polar moment of inertia is denoted I_p , and i_p is the polar radius of gyration: $i_p^2 = I_p/A$. The z -values are measured from the middle of the beam.

If the shear deformations and displacement in the Z -direction are disregarded the deformations of the beam can be described by the displacements u and v in the X - and Y -direction, respectively, and the rotation φ about the Z -axis. The positive directions are shown in figure 2.1.

The beam is simply supported at the ends, i.e. $u = v = 0$ and secured against rotation about the Z -axis, i.e. $\varphi = 0$.

The loading are equal end moments M about the X -axis and central axial end forces N .

In the unloaded state the beam is assumed to have initial curvature and initial torsion corresponding to the initial displacements u_i , v_i and φ_i . The additional displacements from the initial state are determined by the

following differential equations

$$EI_x \frac{d^2 v}{dz^2} = -N(v + v_1) - M \quad (2.01)$$

$$EI_y \frac{d^2 u}{dz^2} = -N(u + u_1) - M\gamma(\varphi + \varphi_1) \quad (2.02)$$

$$(GI_v - Ni_p^2) \frac{d\varphi}{dz} = M \frac{d(u + u_1)}{dz} \quad (2.03)$$

For the torsional expression a solid cross-section has been assumed and the notation

$$\gamma = 1 - EI_y / (EI_x) \quad (2.04)$$

introduced.

In the following the notation GI_{ve} is used for the effective torsional rigidity

$$GI_{ve} = GI_v - Ni_p^2 \quad (2.05)$$

2.2 Analytical solution

The following expressions are assumed for the initial displacements

$$u_i = u_0 \cos \frac{\pi z}{l} \quad (2.06)$$

$$v_i = v_0 \cos \frac{\pi z}{l} \quad (2.07)$$

$$\varphi_i = \varphi_0 \cos \frac{\pi z}{l} \quad (2.08)$$

where u_0 , v_0 and φ_0 are constants.

A more general expression for u_i and v_i would be

$$u_i = u_1 + u_0 \cos \frac{\pi z}{l} \quad (2.09)$$

$$v_i = v_1 + v_0 \cos \frac{\pi z}{l} \quad (2.10)$$

where u_1 and v_1 are constants. A similar constant term in φ_1 is not compatible with the boundary conditions assumed. The constant terms complicate the calculations considerably, and since they will have no real influence on the results in this case they are disregarded.

When (2.06) - (2.08) are inserted the solution of (2.01) is

$$v = \frac{M}{N} \left(\frac{\cos(\sqrt{\frac{N}{N_{Ex}}} \frac{\pi z}{l})}{\cos(\sqrt{\frac{N}{N_{Ex}}} \frac{\pi}{2})} - 1 \right) + v_0 \frac{N}{N_{Ex} - N} \cos \frac{\pi z}{l} \quad (2.11)$$

where N_{Ex} is the euler load corresponding to deflection in the Y-direction (bending about the X-axis)

$$N_{Ex} = \left(\frac{l}{l}\right)^2 EI_x \quad (2.12)$$

A good approximation to (2.11) is

$$v = \frac{M + Nv_0}{N_{Ex} - N} \cos \frac{\pi z}{l} \quad (2.13)$$

The solutions of (2.02) - (2.03) are

$$u = \frac{\left[\frac{N}{N_{Ey}} + \left(\frac{M}{M_{cr}}\right)^2 \right] u_0 + \varphi_0 \gamma \frac{M}{N_{Ey}} \cos \frac{\pi z}{l}}{1 - \frac{N}{N_{Ey}} - \left(\frac{M}{M_{cr}}\right)^2} \cos \frac{\pi z}{l} \quad (2.14)$$

$$\varphi = \frac{\frac{N_{Ey} M}{\gamma M_{cr}^2} \frac{u_0 + \varphi_0 \gamma \frac{M}{N_{Ey}} \cos \frac{\pi z}{l}}{1 - \frac{N}{N_{Ey}} - \left(\frac{M}{M_{cr}}\right)^2}}{\gamma M_{cr}^2} \cos \frac{\pi z}{l} \quad (2.15)$$

where N_{Ey} is the euler load corresponding to deflection in the X-direction

$$N_{Ey} = \left(\frac{\pi}{l}\right)^2 EI_y \quad (2.16)$$

and M_{cr} is the critical moment corresponding to lateral buckling with axial force

$$M_{cr} = \sqrt{N_{Ey} GI_{ve}} / \gamma \quad (2.17)$$

2.3 General expressions for load-carrying capacity

The resulting bending moments about the X- and Y-axis, respectively, in the middle of the beam ($z = 0$), when the approximation (2.13) is used, will be

$$M_x = N(v + v_0) + M = \frac{M + Nv_0}{1 - \frac{N}{N_{Ex}}} \quad (2.18)$$

$$M_y = N(u + u_0) + M(\varphi + \varphi_0) \\ = \frac{\frac{N_{Ey}}{\gamma} \left(\frac{M^2}{M_{cr}} \right) [1 + M\varphi_0 \left[1 - \frac{N}{N_{Ey}} (1 - \gamma) \right]]}{1 - \frac{N}{N_{Ey}} - \left(\frac{M^2}{M_{cr}} \right)} \quad (2.19)$$

Furthermore, shear forces and a torsional moment occur, but they will not be determined since there is a total lack of rupture theories taking the corresponding stresses into consideration.

In the following the simplest possible rupture hypothesis is assumed, namely that rupture starts in the compression zone, and when the following condition is satisfied:

$$\frac{\sigma_c}{f_c} + \frac{\sigma_b}{f_b} = 1 \quad (2.20)$$

where σ_c is the compression stress ($\sigma_c = N/A$), σ_b is the bending stress, f_c is the compression strength and f_b is the bending strength.

To most of the cross-sections used in practice the following expression applies

$$\sigma_b = \frac{M_x}{W_x} + \frac{M_y}{W_y} \quad (2.21)$$

where W_x and W_y are the section moduli. In such cases (2.18) - (2.20) give that the following condition must be satisfied to prevent rupture

$$\frac{N}{f_c A} + \frac{M + Nv_0}{f_b W_x \left(1 - \frac{N}{N_{Ex}} \right)} + \\ \frac{u_0 \left[N + \frac{N_{Ey}}{\gamma} \left(\frac{M^2}{M_{cr}} \right) \right] + M\varphi_0 \left[1 - \frac{N}{N_{Ey}} (1 - \gamma) \right]}{f_b W_y \left(1 - \frac{N}{N_{Ey}} - \left(\frac{M^2}{M_{cr}} \right) \right)} \leq 1 \quad (2.22)$$

The expression contains the usual expressions in the simple cases. For pure bending, however, there is a difference if lateral deflection has not been prevented. Thus, (2.22) gives for $M/M_{cr} = 0$

$$\frac{M}{f_b W_x} + \frac{M\varphi_0}{f_b W_y} = \frac{M}{f_b W_x} \left(1 + \varphi_0 \frac{W_x}{W_y} \right) \leq 1 \quad (2.23)$$

and not

$$\frac{M}{f_b W_x} \leq 1 \quad (2.24)$$

As the bending strength is normally determined by tests without any real lateral support f_b should be determined by (2.24) and not - as it is always done - by (2.25). To take this into consideration the f_b -value to be inserted in (2.22) must be higher than usual and corresponding to the factor $1 + \varphi_0 W_x/W_y$.

3. TESTS

3.1 Test material

Sawn redwood covering the normal Danish structural qualities (Unclassified, T200 and T300 with short-term characteristic bending strengths of 18 MPa, 24 MPa and 30 MPa, according to Danish Standard DS 413) with the cross-sections $b \times h = 38 \times 100$, 50×150 and 38×175 was used. The free lengths were 1560, 2640 and 3720 mm. For each cross-sectional dimension there were 3-6 individual tests. The total number of tests were 39.

Prior to the test the specimens were conditioned indoors at a relative humidity of 65%.

3.2 Test set-up

Compression and/or bending were imposed as shown in fig. 3.1.

The test specimen was supported at the ends by spherical bearings which are further described in relation to fig. 3.2.

At the top the bearing is secured to the loading frame, at the bottom it rests through a load cell on a hydraulic press. The horizontal load is imposed through long rods (R.12) to ensure that the load direction is not changed essentially during the test. At the ends of the test specimen the horizontal reactions are transmitted through a knife bearing resting against the reaction bars (U-120) on a teflon bearing preventing forces from being transmitted perpendicular to the plane of the frame. The horizontal force is made by a hydraulic press and measured through a load cell. The joints at A are thus designed that the reaction bars can move freely in their longitudinal direction (roller bearings). At B only movements perpendicular to the frame were prevented.

The bearings have been developed on the basis of an idea of Massonnet, cf. [3] and [8]. Their principal construction is seen from fig. 3.2 showing the lower bearing. The parts A and B are in the contact area formed as part of a spherical surface. In the lower part a chamber, C, has been milled into which oil is pumped. The oil is pressed out along the contact area so that the upper part comes to rest on an oil film. The surplus oil is gathered in a groove with drainage, D, and pumped back into the chamber..

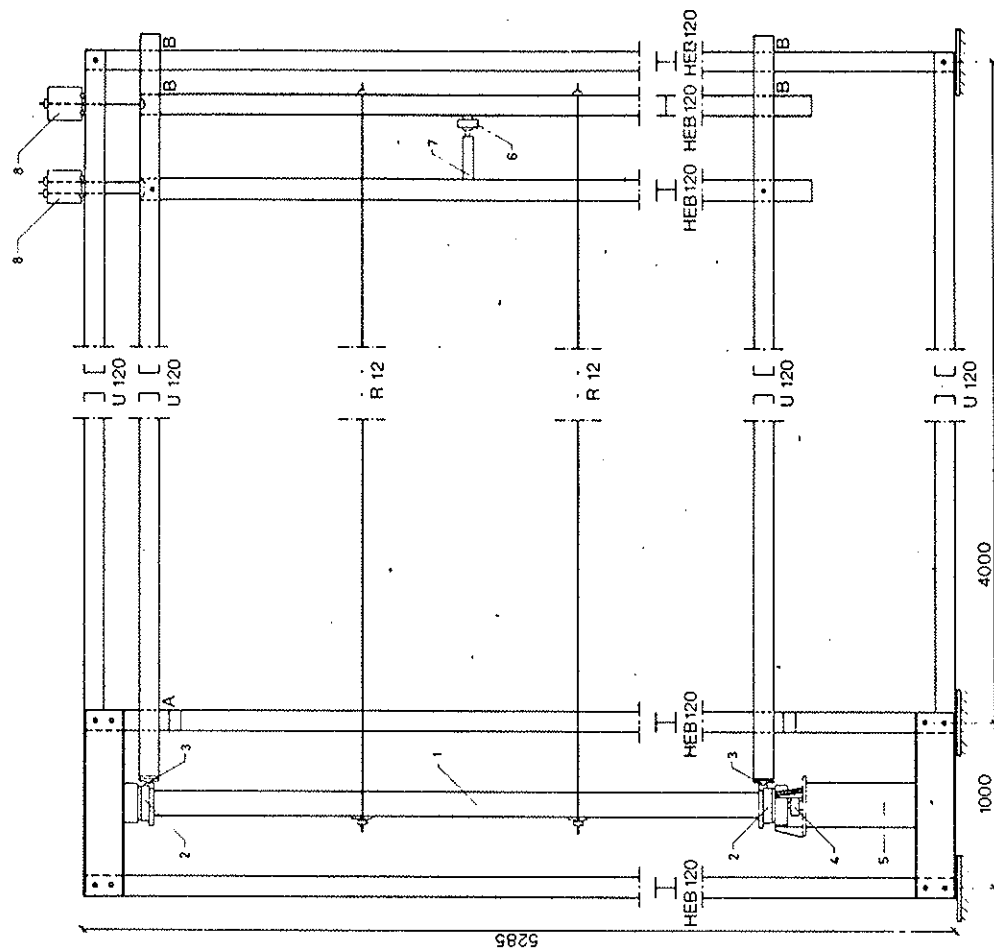

Figure 3.1. Vertical picture. Measurements in mm.

- 1) Test specimen.
- 2) Bearings.
- 3) Combined knife and teflon bearing.
- 4) Load cell.
- 5) Hydraulic press.
- 6) Load cell.
- 7) Hydraulic press.
- 8) Suspension in roller bearings.

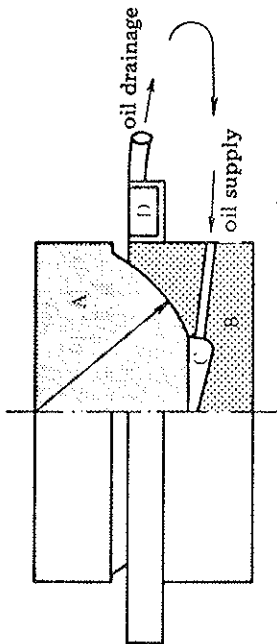

Figure 3.2. Bearings.

The displacements were measured at the bearings and at the middle of the test specimens by electric displacement gauges. At each measuring point two transducers were used at the side of the timber and one at the edge.

3.3 Test procedure

At first the torsional rigidity of the test specimens, i.e. the constant GI_y was determined.

The eccentricities of the test specimen and torsional angle at the middle were determined by plumb-lines, two at the side and one at the edge. The distances from the plumb lines to the timber were measured by a slide gauge at the abutments and at the middle of the test specimen.

In the set-up shown in fig. 3.1 the following tests were then carried out:

1. Pure bending about the weak axis.
2. Pure axial compression without lateral support.
3. Bending about the strong axis.
4. Combined axial compression and bending about the strong axis. The axial force was applied first and then the horizontal load was increased to failure.

For the longest test specimens, 3720 mm, however, the last-mentioned test was not carried out because such weak transversely loaded columns are not used in practice.

By each of the three first-mentioned tests it was aimed at applying the load in 10-20 steps of one minute's duration up to a load by which the timber would not be damaged. In cases where test No. 4 was not used, however, test No. 3 was carried on till rupture. By test No. 4 it was aimed at reaching failure load in 5-10 steps of 1 minute's duration.

After the test a prism about 500 mm long was cut off for determining density and moisture content.

3.4 Test results

The test results are given in table 3.1.

Columns 1-8 contain general information. UK denotes Unclassified. For cross-sectional dimensions only average figures are given from which the deviations were up to 1.5 mm; in the preparation of test results the actual measurements were used. Correspondingly, only mean values are given for the slenderness ratios l/i_x and l/i_y (i_x and i_y are the respective radii of gyration).

The moisture content is not given for the individual tests because the variation (from about 12% to about 15%) does not give rise to adjustment of the other measured quantities.

Column 9 gives the shear modulus G calculated from the measured torsional stress-strain curve. $I_y = b^3 h(1 - 0.63 b/h)/3$ is assumed.

Column 10 gives the modulus of elasticity in bending, E_{by} , determined by test No. 1, cf. section 3.3.

Columns 11 and 16 give the results of the compression test. By the rest related values of the load N and deformation u in the elastic area were measured. If u/N is plotted as abscissa and u as ordinate, cf. fig. 3.3, and if the initial deformations vary sinusoidally, the points will lie on a straight line the slope of which is the column load-carrying capacity N_{Ey} according to the euler formula. The length cut off the ordinate is the initial displacement in the middle, u_0 . Normally the diagram is denoted a Southwell-plot. The modulus of elasticity, E_c , in compression is then determined as $E_c = N_{Ey} l^2 / (\pi^2 I_y)$.

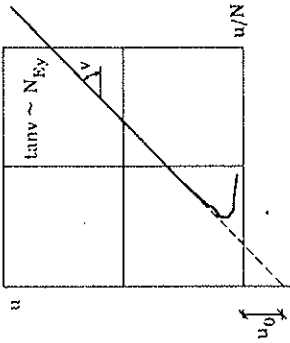

Figure 3.3

Columns 13 and 19 contain the values determined by bending about the strong axis, viz. φ_0 and the bending stiffness EI_x and consequently, E_{bx} . Columns 15-18 give the initial displacements determined from the plumb-line measurements and the compression and bending tests.

Columns 20-21 give the axial force chosen and the moment of failure (M_{meas}) in the final rupture tests.

3.5 Treatment of test results

Mean values, m , and standard deviation, s , for density and moduli of elasticity are given in table 3.2.

	UK		T200		T300		Total	
	m	s	m	s	m	s	m	s
Density	452	39	482	66	489	65	468	65
G MPa	728	58	748	54	827	47	741	65
E_{by} MPa	10050	1330	11690	1920	13920	2680	11180	2160
E_c MPa	8840	1120	10390	1670	12850	2460	9950	2020
E_{bx} MPa	9480	1460	10780	2440	12860	2690	10410	2290

The E_c/E_{by} -ratio is averagely 0.895 with a standard deviation of 0.114. The ratio is significantly higher for the most slender columns (0.99). For comparison the ratio 0.933 with a standard deviation of 0.06 was found in [7].

test no.	qual.	b	h	e	dend.	ϕ/x	ϕ/y	G	E_{by}	E_c	moduli of elasticity		eccentricities		rupture tests	
											E_{bx}	E_{by}	φ_0	φ_0	N	M_{meas}
1.1.1	UK	1200	1.56	0.449	0.409	0.421	702	10720	9040	9270	0.565	0.23	0.23	0.23	12.00	1.82
1.1.2	UK	1200	1.56	0.449	0.409	0.421	702	10720	9040	9270	0.565	0.23	0.23	0.23	12.00	1.82
1.1.3	UK	1200	1.56	0.449	0.409	0.421	702	10720	9040	9270	0.565	0.23	0.23	0.23	12.00	1.82
1.1.4	UK	1200	1.56	0.449	0.409	0.421	702	10720	9040	9270	0.565	0.23	0.23	0.23	12.00	1.82
1.1.5	UK	1200	1.56	0.449	0.409	0.421	702	10720	9040	9270	0.565	0.23	0.23	0.23	12.00	1.82
1.1.6	UK	1200	1.56	0.449	0.409	0.421	702	10720	9040	9270	0.565	0.23	0.23	0.23	12.00	1.82
1.1.7	UK	1200	1.56	0.449	0.409	0.421	702	10720	9040	9270	0.565	0.23	0.23	0.23	12.00	1.82
1.1.8	UK	1200	1.56	0.449	0.409	0.421	702	10720	9040	9270	0.565	0.23	0.23	0.23	12.00	1.82
1.1.9	UK	1200	1.56	0.449	0.409	0.421	702	10720	9040	9270	0.565	0.23	0.23	0.23	12.00	1.82
1.1.10	UK	1200	1.56	0.449	0.409	0.421	702	10720	9040	9270	0.565	0.23	0.23	0.23	12.00	1.82
1.1.11	UK	1200	1.56	0.449	0.409	0.421	702	10720	9040	9270	0.565	0.23	0.23	0.23	12.00	1.82
1.1.12	UK	1200	1.56	0.449	0.409	0.421	702	10720	9040	9270	0.565	0.23	0.23	0.23	12.00	1.82
1.1.13	UK	1200	1.56	0.449	0.409	0.421	702	10720	9040	9270	0.565	0.23	0.23	0.23	12.00	1.82
1.1.14	UK	1200	1.56	0.449	0.409	0.421	702	10720	9040	9270	0.565	0.23	0.23	0.23	12.00	1.82
1.1.15	UK	1200	1.56	0.449	0.409	0.421	702	10720	9040	9270	0.565	0.23	0.23	0.23	12.00	1.82
1.1.16	UK	1200	1.56	0.449	0.409	0.421	702	10720	9040	9270	0.565	0.23	0.23	0.23	12.00	1.82
1.1.17	UK	1200	1.56	0.449	0.409	0.421	702	10720	9040	9270	0.565	0.23	0.23	0.23	12.00	1.82
1.1.18	UK	1200	1.56	0.449	0.409	0.421	702	10720	9040	9270	0.565	0.23	0.23	0.23	12.00	1.82
1.1.19	UK	1200	1.56	0.449	0.409	0.421	702	10720	9040	9270	0.565	0.23	0.23	0.23	12.00	1.82
1.1.20	UK	1200	1.56	0.449	0.409	0.421	702	10720	9040	9270	0.565	0.23	0.23	0.23	12.00	1.82
1.1.21	UK	1200	1.56	0.449	0.409	0.421	702	10720	9040	9270	0.565	0.23	0.23	0.23	12.00	1.82
1.1.22	UK	1200	1.56	0.449	0.409	0.421	702	10720	9040	9270	0.565	0.23	0.23	0.23	12.00	1.82
1.1.23	UK	1200	1.56	0.449	0.409	0.421	702	10720	9040	9270	0.565	0.23	0.23	0.23	12.00	1.82
1.1.24	UK	1200	1.56	0.449	0.409	0.421	702	10720	9040	9270	0.565	0.23	0.23	0.23	12.00	1.82
1.1.25	UK	1200	1.56	0.449	0.409	0.421	702	10720	9040	9270	0.565	0.23	0.23	0.23	12.00	1.82
1.1.26	UK	1200	1.56	0.449	0.409	0.421	702	10720	9040	9270	0.565	0.23	0.23	0.23	12.00	1.82
1.1.27	UK	1200	1.56	0.449	0.409	0.421	702	10720	9040	9270	0.565	0.23	0.23	0.23	12.00	1.82
1.1.28	UK	1200	1.56	0.449	0.409	0.421	702	10720	9040	9270	0.565	0.23	0.23	0.23	12.00	1.82
1.1.29	UK	1200	1.56	0.449	0.409	0.421	702	10720	9040	9270	0.565	0.23	0.23	0.23	12.00	1.82
1.1.30	UK	1200	1.56	0.449	0.409	0.421	702	10720	9040	9270	0.565	0.23	0.23	0.23	12.00	1.82
1.1.31	UK	1200	1.56	0.449	0.409	0.421	702	10720	9040	9270	0.565	0.23	0.23	0.23	12.00	1.82
1.1.32	UK	1200	1.56	0.449	0.409	0.421	702	10720	9040	9270	0.565	0.23	0.23	0.23	12.00	1.82
1.1.33	UK	1200	1.56	0.449	0.409	0.421	702	10720	9040	9270	0.565	0.23	0.23	0.23	12.00	1.82
1.1.34	UK	1200	1.56	0.449	0.409	0.421	702	10720	9040	9270	0.565	0.23	0.23	0.23	12.00	1.82
1.1.35	UK	1200	1.56	0.449	0.409	0.421	702	10720	9040	9270	0.565	0.23	0.23	0.23	12.00	1.82
1.1.36	UK	1200	1.56	0.449	0.409	0.421	702	10720	9040	9270	0.565	0.23	0.23	0.23	12.00	1.82
1.1.37	UK	1200	1.56	0.449	0.409	0.421	702	10720	9040	9270	0.565	0.23	0.23	0.23	12.00	1.82
1.1.38	UK	1200	1.56	0.449	0.409	0.421	702	10720	9040	9270	0.565	0.23	0.23	0.23	12.00	1.82
1.1.39	UK	1200	1.56	0.449	0.409	0.421	702	10720	9040	9270	0.565	0.23	0.23	0.23	12.00	1.82
1.1.40	UK	1200	1.56	0.449	0.409	0.421	702	10720	9040	9270	0.565	0.23	0.23	0.23	12.00	1.82
1.1.41	UK	1200	1.56	0.449	0.409	0.421	702	10720	9040	9270	0.565	0.23	0.23	0.23	12.00	1.82
1.1.42	UK	1200	1.56	0.449	0.409	0.421	702	10720	9040	9270	0.565	0.23	0.23	0.23	12.00	1.82
1.1.43	UK	1200	1.56	0.449	0.409	0.421	702	10720	9040	9270	0.565	0.23	0.23	0.23	12.00	1.82
1.1.44	UK	1200	1.56	0.449	0.409	0.421	702	10720	9040	9270	0.565	0.23	0.23	0.23	12.00	1.82
1.1.45	UK	1200	1.56	0.449	0.409	0.421	702	10720	9040	9270	0.565	0.23	0.23	0.23	12.00	1.82
1.1.46	UK	1200	1.56	0.449	0.409	0.421	702	10720	9040	9270	0.565	0.23	0.23	0.23	12.00	1.82
1.1.47	UK	1200	1.56	0.449	0.409	0.421	702	10720	9040	9270	0.565	0.23	0.23	0.23	12.00	1.82
1.1.48	UK	1200	1.56	0.449	0.409	0.421	702	10720	9040	9270	0.565	0.23	0.23	0.23	12.00	1.82
1.1.49	UK	1200	1.56	0.449	0.409	0.421	702	10720	9040	9270	0.565	0.23	0.23	0.23	12.00	1.82
1.1.50	UK	1200	1.56	0.449	0.409	0.421	702	10720	9040	9270	0.565	0.23	0.23	0.23	12.00	1.82
1.1.51	UK	1200	1.56	0.449	0.409	0.421	702	10720	9040	9270	0.565	0.23	0.23	0.23	12.00	1.82
1.1.52	UK	1200	1.56	0.449	0.409	0.421	702	10720	9040	9270	0.565	0.23	0.23	0.23	12.00	1.82
1.1.53	UK	1200	1.56	0.449	0.409	0.421	702	10720	9040	9270	0.565	0.23	0.23	0.23	12.00	1.82
1.1.54	UK	1200	1.56	0.449	0.409	0.421	702	10720	9040	9270	0.565	0.23	0.23	0.23	12.00	1.82
1.1.55	UK	1200	1.56	0.449	0.409	0.421	702	10720	9040	9270	0.565	0.23	0.23	0.23	12.00	1.82
1.1.56	UK	1200	1.56	0.449	0.409	0.421	702	10720	9040	9270	0.565	0.23	0.23	0.23	12.00	1.82
1.1.57	UK	1200	1.56	0.449	0.409	0.421	702	10720	9040	9270	0.565	0.23	0.23	0.23	12.00	1.82
1.1.58	UK	1200	1.56	0.449	0.409	0.421	702	10720	9040	9270	0.565	0.23	0.23	0.23	12.00	1.82
1.1.59	UK	1200	1.56	0.449	0.409	0.421	702	10720	9040	9270	0.565	0.23	0.23	0.23	12.00	1.82
1.1.60	UK	1200	1.56	0.449	0.409	0.421	702	10720								

The E_{bx}/E_{by} ratio is averagely 0.982 with a standard deviation of 0.106. Also in this case the ratio is higher (1.05) for the most slender columns. Figure 3.4 shows the linear relation found between E and G .

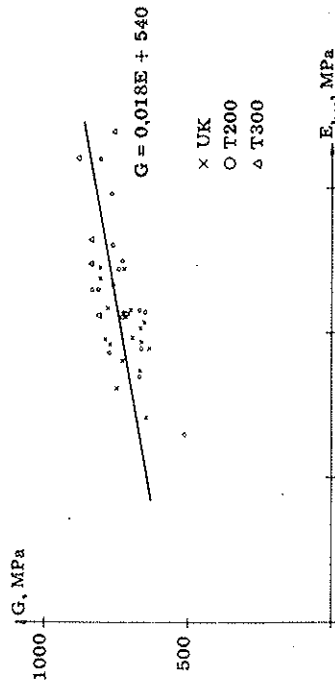

Figure 3.4

In fig. 3.5 the derived initial displacements (numerical values) in relation to core radius in the relevant displacement direction have been drawn. There is very large scatter of the test results and there is no dependence on the quality. Since u_0 and v_0 are partly due to warping caused by shrinkage of the timber, it could be conjectured that they for values above a certain limit will increase by $(\ell/i)^2$. This is confirmed to a reasonable degree by the values found. Two straight lines are shown in the figure. One is $(0.1 + 0.005 \ell/i)$ originating from [6] has been used in various draft codes, among others [1] and [2], and the other $(0.0062 \ell/i)$ is the straight line without constant terms giving practically the same column load-carrying capacity.

For φ no dependence on the length or quality has been found. However, dependence on the b/h -ratio has been found, cf. fig. 3.6, where the numerical values have been plotted. The expression

$$\varphi_0 = 0,05 \frac{b}{h} \tag{3.01}$$

can be assumed.

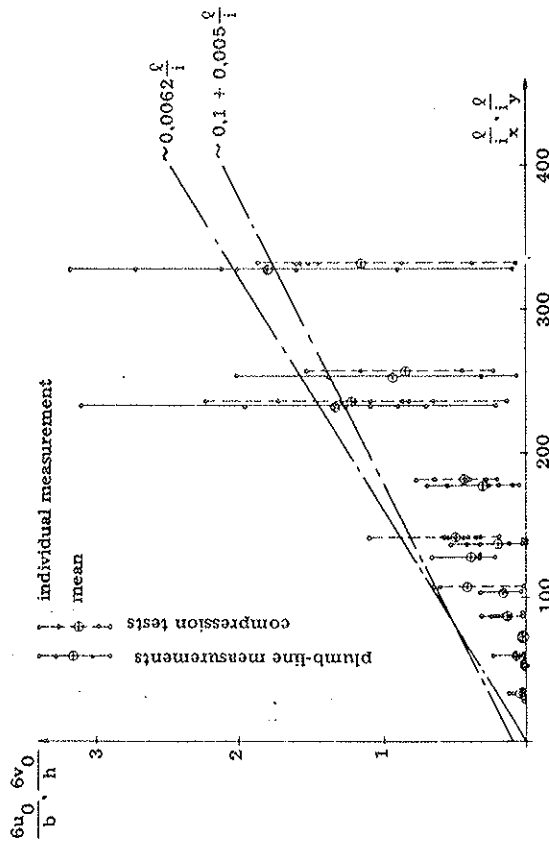

Figure 3.5

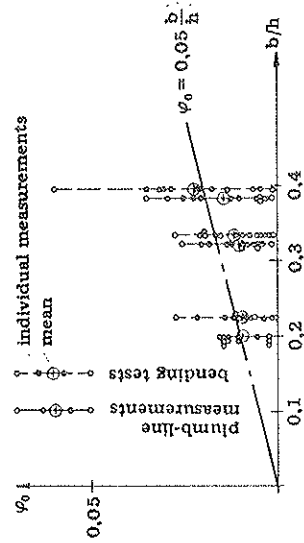

Figure 3.6

Apart from v_0 , which could be determined by a column test with displacement prevented in the Y-direction, the parameters of the expression (2.19) have now been determined for each test. On account of the negligible influence of v_0 in the cases investigated the column test has been omitted and in the following the value found by the plumb-line measurements (table 3.1, col. 17) has been used.

$f_b/f_c = 1.1$ and $f_c = E_{bx}/280$ have been assumed, cf. [6], and the expected rupture moments, M_{cal} , have been calculated by eq. (2.19). The relation between the calculated and measured moments is given in table 3.1, column 23. When test No. 2.3.3 is disregarded an average of $M_{cal}/M_{meas} = 0.960$ with a standard deviation of 0.148 is found. This is a very satisfactory agreement when it is taken into consideration that f_b and f_c have been indirectly determined.

4. DISCUSSION

4.1 Introduction

The tests have shown that the expressions derived can be used to determine the load-carrying capacity when the measured values for the initial displacements are inserted. It can then be assumed that they will also be applicable in setting up expressions for load-carrying capacities from codified or prescribed values. The choice of the initial displacements can be based on the permitted values for bow and twist according to the grading rules. However, these are in most cases very liberal (on these points) and it seems reasonable to use smaller values the observation of which is ensured by stricter requirements of grading or execution for the structures in which it might influence the load-carrying capacity.

As mentioned in relation to figure 3.6 the variation of the initial displacements should immediately be expected to increase with the length squared. Although the use of such variation would give certain advantages (among others the expressions for the load-carrying capacity will mainly be dependent on $\ell h/b^2$ only) the following expression has been assumed

$$\left. \begin{array}{l} u_0 \\ v_0 \end{array} \right\} = 0,0035 \ell \quad (4.01)$$

corresponding to the straight line 0.0062 ℓ/i in figure 3.6.

By choosing a straight line it is possible to get values which are reasonably on the safe side for short or medium-slender structures (the influence of the eccentricities is greater for medium-slender structures) without getting unreasonably high values for the slender ones.

4.2 Pure lateral buckling

Initially, among others to estimate the influence of the parameter φ_0 , the case of pure lateral buckling is considered, i.e. $N = 0$. The ultimate value of the end moments taking lateral bending into consideration is denoted M_{cr} , while M_0 is the ultimate moment in pure bending

$$M_0 = f_b W \quad (4.02)$$

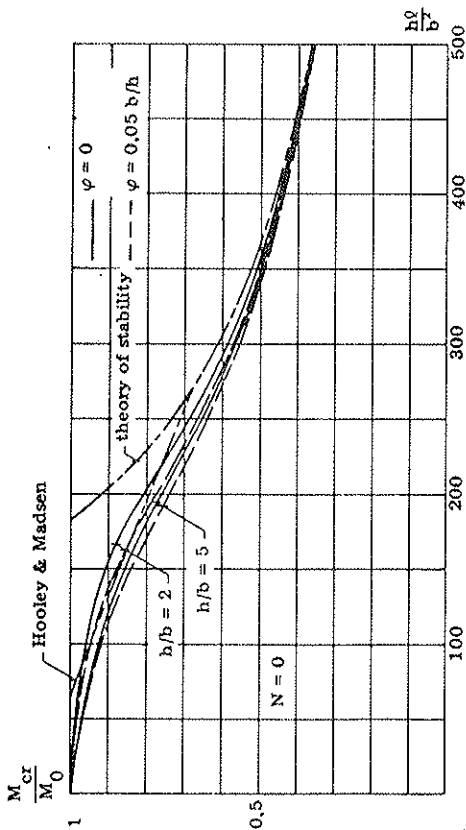

Figure 4.1

In fig. 4.1 M_{cr}/M_0 has been drawn dependent on h^2/b^2 for $h/b = 2$, $h/b = 5$ and for $\varphi_0 = 0$ and φ_0 equal to the value found by the tests, viz.

$$\varphi_0 = 0.05 b/h$$

cf. (3.01). $E/f_c = 280$ and $E/G = 16$ have been assumed.

For the case $\varphi_0 \neq 0$ a correction factor for the normal bending strength of

$$1 + \varphi_0 W_x/W_y = 1 + 0,05 = 1,05 \tag{4.03}$$

has been assumed, cf. the text below formula (2.25).

With the scatter of the properties of structural timber it is seen that a single common curve e.g. corresponding to $\varphi_0 = 0$ and $h/b = 3$ can be used.

The assumption of $\varphi_0 = 0$ facilitates the calculations and furthermore, it is not necessary to distinguish between beams with lateral deflection prevented and non-restrained beams of a length where lateral buckling is not relevant.

Fig. 4.1 also shows M_{cr}/M_0 corresponding to the classical stability theory, formula (2.17), and the approximation given by Hooley & Madsen [4].

4.3 Combined loading

As shown in the above (2.22) with $\varphi_0 = 0$ can be used as a general expression. The use of the formula will be a little complicated for ordinary engineering practice, but it is easy to work out diagrams which will simplify the calculations very much.

An example is shown in fig. 4.2. The diagram gives M/M_0 dependent on N/N_0 , the h/b -ratio and the slenderness ratio ℓ/i_y , corresponding to the weak direction. N_0 is the axial force corresponding to the compression strength

$$N_0 = Af_c \tag{4.04}$$

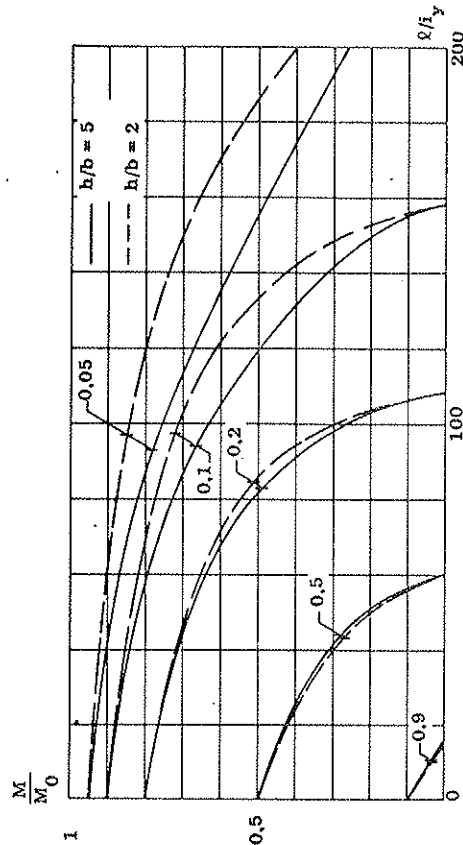

Figure 4.2. The values on the curves state N/N_0 .

The same results as given in fig. 4.2 are shown in fig. 4.3, however, also including $h/b = 1$.

The acceptable combinations can with reasonable approximation for practical use be determined from the following equations

$$\left. \begin{aligned} \frac{N}{N_{cr}} + \frac{M}{M_0} &\leq 1 \\ M/M_{cr} (N=0) &\leq 1 \end{aligned} \right\} \tag{4.05}$$

CONTENTS

For *-marked chapters no draft is available so far. The others are included in FIRST DRAFTS 76.04.20 and January 1977 (CIB paper 6-100-2 and 7-100-1).

1. INTRODUCTION

1.1 Scope

1.2 Conditions for the validity of this document

1.3 Units

Reference to ISO

* 1.4 Notations

Symbols to be chosen in accordance with ISO 3898. As a basis for determination of the special timber symbols »Symbols for use in structural timber design», CIB-Documents CIB-W18-1, June 1976, is used. The final list cannot be worked out until the final editing

* 1.5 Definitions

To be worked out during the work with the code

2. BASIC ASSUMPTIONS

2.1 Characteristic values

Choice of percentile-values for strength calculations and for stiffness calculations

2.2 Climate classes

2.3 Load duration classes

3. BASIC DESIGN RULES

* 3.0 General

A draft has been prepared (1. draft, 3.0, 3.2 and 3.4). It will be necessary to await clarification of the general principles in ISO TC 98 before the special conditions valid for timber structures can be treated. This section also comprises requirements of deflections, mainly by reference to ISO

3.1 Design by calculation

3.1.1 Basic assumptions

Application of the theory of elasticity/theory of plasticity. Allowable simplifications

3.1.2 Cross-sectional dimensions

Acceptable deviations between true dimensions and those used in calculations

* 3.1.3 Partial coefficients for materials

To be determined on the basis of ISO TC 98 to the extent it is not a national or governmental matter

3.2 Design by testing

3.2.0 General

3.2.1 Execution of tests

* An independent standard is on the RILEM/CIB work programme

3.2.2 Determination of characteristic ultimate value

Requirements of the statistical treatment of the test results

* 3.2.3 Partial coefficients

As 3.1.3

4. REQUIREMENTS OF MATERIALS

4.1 Structural timber

Structural timber is classified on the basis of the characteristic bending strength. The following classes are proposed for European softwood:

T18 T24 T30

Regarding hardwood the following classes could be proposed:

T40 T50 T60

It is left to the regional or national organizations to set up the grading rules. No differentiation is made between ordinary timber and finger-jointed timber.

4.2 Glulam

Glulam is classified as structural timber. The following classes are proposed for European softwood:

GL30 GL40 GL50

The classification can be extended when necessary.

It is left to the regional or national organizations to set up requirements of lamellas and cross-sections to obtain a given class

4.3 Plywood

It is demanded that the production must be subject to a recognized control arrangement and that strength parameters are determined on the basis of testing according to ISO

4.4 Other wood-based panels

As for plywood

4.5 Glue

4.6 Mechanical fasteners

Reference is made to section 5.3

5. DESIGN OF BASIC MEMBERS

5.1 Structural timber

★

5.1.0 Strength and values

For the classes mentioned in section 4.1 characteristic strength and stiffness parameters for strength and deformation calculations are given for the climate and load duration classes determined in section 2

5.1.1 Beams and columns

5.1.1.1 Pure tension

5.1.1.2 Pure compression without column effect

5.1.1.3 Pure bending

Including depth-factor and lateral instability

5.1.1.4 Shear

Including notch effect

5.1.1.5 Tension and bending

5.1.1.6 Compression and bending without column effect

5.1.1.7 Compression and bending with column effect

5.2 Glulam

5.2.1 Beams and columns

As 5.1.1

5.2.2 Curved members

Effect of bending of lamellas, distribution of bending stresses, tension perpendicular to the grain

5.2.3 Cambered beams straight or pitched

5.3 Joints

All load-carrying capacity expressions etc. are given in a general form where the parameters are inserted dependent on the values for timber and material of the fasteners

5.3.0 General

General requirements, determination of characteristic load-carrying capacities (reference to ISO, and ISO, protection against corrosion

5.3.1 Nails

Laterally loaded nails (timber to timber, board materials to timber, steel to timber, withdrawal strength)

5.3.2 Bolts and dowels

5.3.3 Screws

5.3.4 Connected joints

5.3.5 Glued joints

5.3.6 Construction rules

6. DESIGN OF COMPONENTS AND SPECIAL STRUCTURES

6.1 Glued components

6.1.1 Thin-webbed beams

6.1.2 Thin-flanged beams (stiffened plates)

6.1.3 I- and box columns, spaced columns, lattice columns

6.2 Mechanically jointed components

Subdivision as for section 6.1

6.3 Arches, portals and frames

6.4 Trusses

INTERNATIONAL COUNCIL FOR BUILDING RESEARCH STUDIES AND DOCUMENTATION

WORKING COMMISSION W18 - TIMBER STRUCTURES

CIB TIMBER CODE -- LIST OF CONTENTS (SECOND DRAFT)

H J Larsen

Bruxelles

October 1977

7. EXECUTION

★ 8. CONTROL

INTERNATIONAL COUNCIL FOR BUILDING RESEARCH STUDIES AND DOCUMENTATION

WORKING COMMISSION W18 - TIMBER STRUCTURES

POLISH STANDARD PN-73/B-03150: TIMBER STRUCTURES;
STATISTICAL CALCULATIONS AND DESIGNING

Bruxelles

October 1977

UNOFFICIAL TRANSLATION

POLISH STANDARD

TIMBER STRUCTURES
STATICAL CALCULATIONS AND DESIGNING

PN - 73/B - 03150



1. INTRODUCTION

1.1. Subject of the standard.

The subject of the standard are the rules of statical calculations and timber structures designing.

1.2. Application range of the standard. The standard should be applied in all timber structures in building. It is not applied in bridge constructions.

1.3. Standards and connected documents.

- PN-74/B-02009 Loads in statical calculations. Permanent and changing load.
 PN-70/B-02010 Loads in statical calculations. Snow loads
 PN-70/B-02011 Loads in statical calculations. Wind loads
 PN-69/B-03000 Building designs, Statical calculations
 PN-64/B-03001 Structures and building base. Rules of designing and statical calculations.
 PN-76/B-03200 Steel structures. Statical and designing calculations
 PN-75/D-01001 Sawn timber. Classification, terminology
 PN-74/D-02002 Fibreboards. Terminology
 PN-75/D-02003 Plywood. Classification and terminology
 PN-57/D-96000 Softwood of general application
 PN-72/D-96002 Hardwood of general application
 PN-71/D-97003 Plywood of general application
 PN-72/H-84020 Ordinary structural coal steel of general application. Types.
 PN-76/H-92225 Hoop iron without covering or galvanized
 PN-75/H-93200.00 Wire rod and round hot rolled steel bars. Dimensions
 PN-75/H-93200.02 Wire rod and round and hot rolled steel bars. Bars of general application. Dimensions.
 PN-67/M-81000 Nails. General requirements and research.
 PN-5/M-82010 Square washers in timber structures
 PN-7/M-82101 Hexagon bolts
 PN-73/M-82121 Square bolts
 PN-75/M-82144 Hexagon nuts
 PN-75/M-82151 Square nuts
 PN-72/M-82501 Hexagon head screws
 PN-72/M-82502 Square head screws
 PN-72/M-82503 Cone head screws
 PN-72/M-82504 Lentil head screws
 PN-72/M-82505 Round head screws
 PN-72/M-82509 Screws for timber. General requirements and research
 BN-70/5028-12 Building nails. Round and square section nails
 BN-70/5028-19 Building nails. Square twisted pallet nails.
 BN-66/7113-10 Shuttering plywood
 BN-74/7122-11.21 Fibreboards. Ordinary harboards. Specifications.
 BN-74/7122-11.22 Fibreboards. Very hard boards. Specifications

Technical instruction regarding surface protection of building timber - Instytut Techniki Budowlanej/Institute of Building Technology/, Warsaw 1957

Instruction concerning complex protection of building timber against biological pests and fire - Instytut of Building Technology, Warsaw 1969.

2. MATERIALS

2.1. Timber

2.1.1. Timber in structural elements should be softwood: pine or spruce. If necessary, it is possible to apply fir, larch and hardwood: poplar or alder.

2.1.2. Inserts, pins, blocks and other small structural elements should be made of oak, acacia or other similarly hard and lasting kinds of timber.

2.1.3. Assortments, classification of sawn timber as regards its quality. Specifications - according to PN-75/D-01001, PN-57/D-96000 and PN-72/D-96002.

2.1.4. Minimum instantaneous strength of standard samples of pine wood and spruce wood should be smaller than in Table 1. If timber strength has been examined at the dryness $W\%$ different from 15%, so that $15 < W < 23$, then strength corresponding with dryness 15% is calculated according to the formula

$$K_{15} = [1 - \alpha_W (W - 15)] K_W \quad //$$

where:

K_{15} - strength of timber with dryness of 15%, kg/cm^2

K_W - strength of timber with dryness $W\%$, kg/cm^2

α_W - coefficient acc. to Table 2

Table 1. Minimum instantaneous strengths of pine or spruce

kind of strength	symbol	Strength kg/cm^2
bending	K_g	500
tension along the grain	K_r	550
compression pressure along the grain	K_c, K_d	300
Shear along the grain	K_t	40
compression across the grain	K_{\perp}	20

Table 2. Coefficients α_W

kind of strength	pine larch	spruce oak fir
compression along the grain	0,05	0,04
bending	0,04	0,04
shear along the grain	0,03	0,03

2.1.5. Dryness of timber

2.1.5.1. Permissible dryness of softwood applied in structural elements depends on where they are built in and on the kind of joints. Dryness should not exceed:

a/ for structures protected against moisture - 20%

b/ for structures in the open air - 23%

c/ for glued structures - 15% and it should comply with glueing technology

2.1.5.2. Dryness of hardwood applied for inserts, pins, blocks ect. should not exceed 15%

2.1.6. Coefficients of elasticity and deformation should be taken into account in the calculation of deformations according to Table 3.

Table 3. Coefficients of elasticity and deformation

E, G

kind of timber	Coefficient of elasticity E, kg/cm ²		Coefficient of deformation G, kg/cm ²
	parallel to the grain	perpendicular to the grain	
	bending tension compression	compression	
pine, spruce	100000	3000	5000
oak, acacia, beech, birch	125000	6000	10000

With structures exposed to humidity for a long time, coefficients E and G should be adopted with the corrector coefficient 0,8

2.2.1. Grade/quality of timber for load-bearing elements shall be shown on figures and on lists of materials.

2.2.2. Timber defects for elements of timber structures in respective categories, made of sawn materials shall not be greater than it is shown in the appendix to this standard.

2.3 Plywood

2.3.1. Plywood applied in structures should be water-resistant, made of hardwood or in exceptional cases of pine-wood.

2.3.2. Appointments and classification of plywood - according to PN-75/B-02003, PN-71/D-97003 and BN-66/7113-10

2.3.3. Thickness of plywood should be at least:

- 3 mm - for structures
- 12 mm - for gusset plates of truss, girders
- 9 mm - for roof and wall panels

2.3.4. The elasticity coefficient of plywood along the grain of the facing board should be $E_{sk} = 70\ 000\ \text{kg/cm}^2$ and across the grain of the facing board $E_{sk} = 30\ 000\ \text{kg/cm}^2$. The deformation coefficient $G_{sk} = 5000\ \text{kg/cm}^2$ is adopted. In case of long lasting moist conditions the values E and G should be diminished with the use of a corrector coefficient 0,8

2.3.5. Instantaneous strength of plywood with dryness 15% should not be smaller than this in Table 4

Table 4 Minimum instantaneous strength of plywood, made of hardwood, water resistant and glued with synthetic glues

number of veneers in a plywood	instantaneous strength, kg/cm^2			
	bending		tension	compression
	along the grain of the facing board	across the grain	along the grain	
≥ 5	550	450	450	330

For a pine plywood, water resistant, the values should be adopted with the coefficient 0,8

2.3 Fibreboards

2.3.1. Types of boards. In timber structures it is possible to apply hard and very hard fibreboards which meet the requirements of PN-74/D-02002 and BN-74/7122-11.21 and 22.

2.3.2. The elasticity and deformation coefficients E and G should be adopted: for hard boards $E_T = 30\ 000\ \text{kg/cm}^2$, for very hard boards $E_{BT} = 40\ 000\ \text{kg/cm}^2$

In the deformation calculations the elasticity coefficient should be adopted with the use of a corrector coefficient 0,5

The Poisson's coefficient for hard and very hard boards should be adopted $\mu = 0,15$.

The deformation coefficient in deformation calculations and taking into account cooperation with timber should be adopted: for hard boards $G_T = 3500\ \text{kg/cm}^2$, for very hard boards $G_{BT} = 5000\ \text{kg/cm}^2$.

When a structure is exposed to higher moisture of air for a long time/65% S.R., the values E and G should be multiplied by coefficients: for hard boards - 0,4, for very hard boards - 0,5.

2.3.3. Minimum instantaneous strength of fibreboards with dryness 15% should not be smaller than this in Table 5.

Table 5. Minimum instantaneous strength of hard and very hard fibreboards

kind of board	thickness mm	weight by volume kg/m^3	instantaneous strength kg/cm^2				
			bending	tension	shear in the board surface	in the perpendicular direction	compression
hard	3,2	1000	350	200	200	10	180
very hard	4,0 5,0	1050	400	250	250	11	200

2.4. Ancillary materials

2.4.1 Connectors

2.4.1.1. Bolts - PN-74/M-82101 and PN-73/M-82151.

2.4.1.2. Nuts for bolts - PN-75/M-82101 and PN-75/M-82151.

2.4.1.3. Screws - PN-72/M-82501, PN-72/M-82502, PN-72/M-82504, PN-72/M-82504, PN-72/M-82505 and PN-72/M-82509.

2.4.1.4. Nails - PN-67/M-81000, BN-70/5028-12 and BN-70/5028-19.

2.4.1.5. Inserts, plates ect. Connectors should be made of coal steel of ordinary quality and applied according to PN-72/R-84020 or of other materials with mechanical parameters not smaller than the parameters of hardwood.

Toothed inserts, for instance toothed rings, as it is recommended, should be made of steel 18G2.

2.4.1.6. Structural glues should be water resistant. The caseine glue may be applied only in connections between timber structures protected against moisture or placed in rooms in which relative humidity does not exceed 65%.

2.4.2. Impregnating materials for timber and timber derived materials protecting against biological corrosion and fire should be applied in compliance with the instruction of ITB/Institute of Building Technology/ - "Technical Instruction on surface protection of building timber" and "Instruction on complex protection of building timber against biological pests and fire". The protected places should be indicated on working figures and discussed in technical descriptions.

Fire preventive means, flame retardants should be applied, in cases when a proper class of fire resistance of a structure is required or when it is necessary to obtain an unflamable material.

2.4.3 Materials protecting timber against chemical aggression. Timber, plywood and fibreboards should be protected against chemical corrosion, when timber structures are to be used in chemically aggressive environment. Corrosion preventive materials should have a certificate of permission for their application in building.

2.4.4 Protection of timber structures against statics should be in compliance with the Instruction 16 according to 1.3.

3. PROVISIONS FOR CALCULATIONS AND DESIGNING

3.1 General rules. Statical calculations should be performed according to PN-69/B-03000 and this standard.

Calculations based on other provisions than those given in the standard are permitted and it is possible to adopt different rules of designing provided that they are justifiable from the scientific and economic point of view.

3.2 Method of calculation. Statical calculations should be performed, according to PN-64/B-03001, with the method of limit states.

There are two limit states:

- a/ Limit state as regards the structure damage /exceeding the strength limit, the loss of stability/ under the design load
- b/ Limit state as regards deformation or dislocation under the standard load/without the overload coefficient/.

3.3 Load distribution In calculations for timber structures one should take into consideration the main and the additional loads according to PN-70/B-02010 and PN-70/B-02011. Structural loads should be discussed in their least favourable distribution during exploitation and at separate construction stages.

3.4 Categories of structural elements. Structural elements are assigned to one of the four categories /Table 6/ according to a kind of work.

3.5 . Weight of trusses G_w can be approximately determined in KG/m^2 by the formula

$$G_w = L$$

where: L - span, m.

When the real weight of a structure differs from the assumed one by more than 10%, it is necessary to correct the calculations.

Table 6 Categories of structural elements

Category of structural elements	Kind of elements work	Assortments	Recommended class / quality of timber
1	2	3	4
A	<p>I. Elements with mechanical connectors</p> <p>a/ elements tensioned axially or eccentrically b/ elements tensioned in bent composite beams</p>	boards, planks, square sawn timber	III II
B	<p>a/ elements compressed axially or eccentrically and bent elements such as bars of trusses, purlins ect. b/ inventory boards for concrete or reinforced concrete structures c/ elements tensioned axially or eccentrically in which stress does not exceed 70% of calculation strength</p>	boards, planks, square sawn timber	IV II
C	<p>a/ bent elements with movable load/temporary/ such as working platforms, roof boarding b/ ordinary boarding for concrete or reinforced concrete structures c/ secondary tensioned elements, the failure of which is not followed by dangerous changes in a load-bearing structure</p>	boards, planks, square sawn timber, beams	V III
A	<p>II. Glued elements</p> <p>Tensioned elements and the tensioned zone of laminated bent elements/not smaller than 0,15 of the height of the cross-section from the tensioned edge/ with the height of above 50 cm and tensioned flanges of I - girders/ Fig. 39 a, d, e/</p>	boards, planks	III
B	<p>a/ as above but with the possibility of applying calculation strength only up to 70% b/ compressed and tensioned zone/with the height not smaller than 0,15 of the height of the cross-section from the extreme tensioned edge or 0,10 from the compressed edge/ of bent elements, compressed axially and eccentrically such as: compressed flanges, grate elements of lattice girders, arch girders, laminated beams with the height up to 50 cm, compressed zone of laminated beams with the height above 50 cm, flanges of I - beams with the chopping timber web / Fig. 39 b, c, d, f/ ect, with the use of the standard strength of timber above 70%</p>	boards, planks	IV
B ¹	as b/ but with the possibility of using standard strengths only up to 70%	boards, planks	IV/V
C	Central zone of the cross-section of laminated bent elements, compressed and eccentrically compressed and webs of I - beams of chop timber boards/ Fig. 39 b, c, d, f/	boards, planks	V
<p>1/ The quality of timber for load-bearing elements should be shown on figures and lists of materials. Timber defects in separate classes of quality are to be found in the appendix to the standard.</p>			

... elements and connections of timber structures are calculated, if the elastic work of a material is assumed.

... deformations of timber structures are calculated, if the elastic work of a material is assumed and taking into account flexibility of connections.

2.8 Standard strength of timber

2.8.1. Values of standard strengths K are defined according to the minimum instantaneous strength of timber with the formula

$$K = k_{\min}^{dor} \cdot k_d \cdot k_j \quad /3/$$

where:
 k_{\min}^{dor} - minimum instantaneous strength of pine or spruce according Table 1, kg/cm^2 ,
 $k_d = 0,67$ - corrector coefficient to the instantaneous strength determining the influence of the long duration of loading,
 k_j - coefficient of homogeneity according to Table 7.

The standard strength K for pine or spruce should be adopted according to Table 8 and Fig.1

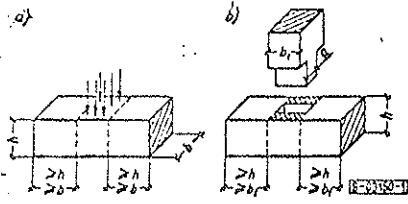

Fig. 1.

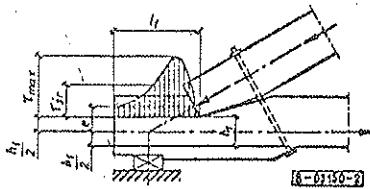

Fig. 2.

Table 7. Coefficients of homogeneity k_j

kind of strength	coefficient k_j
bending	0,40
tension along the grain	0,27
compression and pressure along the grain	0,65
compression and pressure across the grain	0,90
shear along the grain and at the acute angle to the direction of the grain	0,70

Table 8. Standard strengths of pine and spruce

	kind of strength	sym- bol	strength
1	2	3	4
1	bending: a/ elements of solid timber/except p.b/ b/ elements of timber with a side $\geq 14\text{cm}$ and height h to 50 cm c/ glued elements regardless of height but with the side 14 cm d/ round timber, not weakened on edges with indentations, in a section under consideration	K_b	130 150 150 160
2	Tension along the grain	K_r	100
3	Tension across the grain	K_r^{\perp}	4
4	Compression and pressure along the grain	K_c	130
5	Compression and pressure on the whole surface across the grain	K_d	12
6	Pressure across the grain in a/ in support planes of structures b/ on part of the surface, if there is any left - in the direction of the grain - free ends whose length is not smaller than the height of the pressed element and the length of the pressure surface (Fig. 1a, b) in frontal cuts, blocks and inserts. c/ under bolt washers with the pressure at the angle $\alpha = 90^\circ$	K_d	24 30 40
7	Pressure at the acute angle to the grain	$K_{d\alpha}$	acc to table 9
8	shear along the grain a/ with bending b/ in connections with frontal cuts and blocks -maximum -medium	K_t K_t^{max} K_t^{sr} K_t	12 24 acc. to form. 6

Table 8 continued

9	shear across the grain /maximum/	K_t^I	12
10	shear at the acute angle to the direction of the grain	$K_{t\alpha}$	acc. table 10
11	cutting in the cross-section	K_p	50

In temporary structures standard strengths can be increased by 20%.

In countrybuilding of temporary character for carpenter structures with the span to 10,5 m with mechanical connectors/nails, pins, toothed plates ect. it is possible to apply worse classes of timber/without increasing the strength/: III/IV instead of IIII, IV/V instead of IV, Incipient decay is permitted only on the surfaces of the class V.

3.8.2 Particular cases of standard strengths

3.8.2.1 Standard strength $K_{d\alpha}$ with the pressure at the acute angle to the grain is defined with the formula

$$K_{d\alpha} = \frac{K_c}{1 + \left(\frac{K_c}{K_d} - 1\right) \sin^3 \alpha} \quad 4/$$

where K_c should be replaced with one of the four values of the pressure according to Table 8 nr 5 and 6

Values $K_{d\alpha}$ calculated for pine and spruce according to the formula /4/ are shown in Table 9.

Table 9. Standard strengths $K_{d\alpha}$ of the pressure at the angle α to the direction of the grain for pine and spruce

angle α°	Strength in relation to a respective point of Table 8, kg/cm^2			
	nr.5	nr.6a/	nr6b/	nr.6c/
0	130,0	130,0	130,0	130,0
5	130,0	130,0	130,0	130,0
10	125,5	127,2	127,2	127,5
15	118,1	122,0	123,0	125,0
20	104,0	110,0	114,5	119,0
25	88,3	97,2	103,5	111,0
30	73,2	83,8	91,8	101,2
35	59,7	71,2	79,7	91,2

Table 9 continued

40	49,0	59,7	69,5	81,3
45	40,8	50,6	60,0	72,4
50	33,4	43,5	52,5	65,0
55	29,5	36,8	46,1	58,3
60	25,8	33,6	43,3	52,8
65	23,1	30,2	37,5	48,6
70	21,1	27,8	34,8	45,5
75	19,8	26,0	32,7	42,8
80	18,7	24,8	31,2	41,5
85	18,2	24,2	30,4	40,4
90	18,0	24,0	30,0	40,0

3.8.2.2 Standard strength $K_{t\alpha}$ with the shear at the acute angle to the direction of the grain is defined with the formula

$$K_{t\alpha} = \frac{K_t}{1 + \left(\frac{K_t}{K_t^I} - 1\right) \sin^3 \alpha} \quad 5/$$

where

K_t, K_t^I - standard strengths with shear according to Table 8.

Values $K_{t\alpha}$ calculated for pine and spruce according to formula/5/ are shown in Table 10.

Table 10. Standard strengths $K_{t\alpha}^{\text{max}}$ of the shear at the angle α to the direction of the grain, for pine and spruce

α°	$K_{t\alpha}^{\text{max}}$ kg/cm^2	α°	$K_{t\alpha}^{\text{max}}$ kg/cm^2	α°	$K_{t\alpha}^{\text{max}}$ kg/cm^2	α°	$K_{t\alpha}^{\text{max}}$ kg/cm^2
5	24,0 ^{1/}	36	19,9	47	17,3	58	14,9
10	23,8	37	19,7	48	17,0	59	14,6
15	23,5	38	19,5	49	16,8	60	14,5
20	22,8	39	19,2	50	16,6	65	13,7
25	22,4	40	18,9	51	16,3	70	13,2
30	21,4	41	18,7	52	16,1	75	12,7
31	21,4	42	18,5	53	15,8	80	12,2
32	20,9	43	18,2	54	15,6	85	12,0
33	20,6	44	18,0	55	15,6	90	12,0 ^{2/}
34	20,4	45	17,8	56	15,3		
35	20,2	46	17,6	57	15,1		

1/ according to Table 8, p. 6b/;

2/ according to Table 8, p. 9.

PN-73/B-03150

3.9.2 Standard strength on the wall K_t^{sr} in connections with uniform distribution of stresses in the plane of shear in connections with gains, blocks ect./is defined with the formula /6/ and Fig.2.

$$K_t^{sr} = k_t K_t^{max} \quad /6/$$

where k_t - reduction coefficient according Table 11

K_t^{max} - standard strength with shear according Table 10.

Table 11. Reduction coefficients k_t to bearing stresses in the calculations of connections on the wall according to the formula/6/

$\frac{l_t}{e}$	tensioned elements of connections	compressed elements of connections and inserts /blocks, rings/
3	0,57	0,73
4	0,50	0,67
5	0,44	0,62
6	0,40	0,57
8	0,33	0,50
10	0,29	0,44

l_t - length of the plane of shear
 e - arm of shear forces equal to the distance between the shearing force and the axis running through the centre of the weakened section

3.9 Standard strength of plywood

3.9.1. Types of standard strengths of water resistant plywood are shown in Table 12.

Table 12. Standard strengths of softwood water resistant plywood

	Type of strength	sym- bol	strength, kg/cm ²	
			along the grain	perpendicular to the grain
1	Perpendicular bending to the plywood plane	K_g^\perp	140	60
2	bending in the plywood plane	K_g	110	75
3	tension in the plywood plane	K_r	100	50

Table 12 continued

4	compression in the plywood plane	K_c	100	50
5	compression perpendicular to the plywood plane	K_c^\perp	38	38
6	shear in the plywood plane	K_t	11	11
7	cutting perpendicular to the plywood plane	K_c^\perp	60	60

The number of veneers/layers/ in the plywood should not be smaller than 5

3.9.2 Standard strength /resistance/ to compression and tension at an angle.

With a force at the angle α to the direction of the grain of plywood facing boards, the standard resistance/strength/ to compression and tension should have values:

- a/ for $\alpha = 0^\circ$ $K = 100 \text{ kg/cm}^2$,
- b/ for $\alpha = 30^\circ$ to 60° $K = 25 \text{ kg/cm}^2$ /permanent value for this range/
- c/ for $\alpha = 90^\circ$ $K = 50 \text{ kg/cm}^2$

Intermediate values of strength for angles $\alpha = 30^\circ$ and $\alpha = 60^\circ$ to 90° should be interpolated linearly.

3.10 Standard strength of fibreboards

3.10.1 Kinds of standard strengths of hard and very hard fibreboards according to EN-74/7122-11,21 and 22 are shown in Table 13.

Table 13. Standard strengths K for fibreboards/for boards acc. Table 5/

kind of strength	sym.	strengths of fibreboards, kg/cm ²	
		hard	very hard
tension	K_r	50	60
bending	K_g	100	100
compression	K_c	50	60
shear in the board plane	K_t	4	4
shear perpendicular to the board plane	K_t^\perp	20	30

PH-73/B-03150

Calculation strength of fibreboards in the conditions of higher humidity. When a structure is exposed to higher humidity of air/65% - 90%, the values from Table 13 should be multiplied by the coefficient 0,4 for hard boards or 0,5 for very hard boards.

Calculation strength of timber. Calculation strength of timber is determined by multiplying standard strengths R_k by the corrector coefficient m

$$m = m_1 m_2 m_3 m_4 \quad /7/$$

where:

- m_1 - coefficient taking into account the conditions of work of a structure under the load of short duration/ Table 14/,
- m_2 - coefficient taking into account the conditions of a structure usage
- m_3 - coefficient taking into account the kind of timber in relation to pine and spruce /Table 16/
- m_4 - coefficient taking into account a previous flexion of an element/ Table 17/.

Table 14. Coefficients m_1 of the conditions in which the structure works

kind of load	for all kinds of strength except the pressure across the grain	for pressure across the grain
wind	1,2	1,4
assembly	1,2	1,4
seismic	1,4	1,6

When it is difficult to select a proper section one is permitted to exceed calculation strengths but by no more than 5%.

3.12 The way of expressing values in units of measurement of the SI. system, while expressing values in units of measurement of the SI. system the following relations between units of measurement should be applied:

- 1 kg = 9,80665/exactly/
- 1 kg/cm² = 98,0665 kN/m²/exactly/
- 1 kg*cm = 98,0665 mN*m/exactly/

Approximate relations are permitted:

- 1kg = about 10 N or about 1 daN,
- 1kg/cm² = about 100kN/m² or about 0,1mN/m²
- 1kg*cm = about 0,1 N*m Or about 100mN*m.

4. DESIGNING

4.1. Maximum ambient temperature, in which it is possible to apply timber structures should not exceed 55° C.

4.2. The smallest net cross-section of the solid member of permanent load-bearing structure with the exception of roof battens should not be smaller than 40cm², with thickness not smaller than 38mm. In timber structures with nail connectors or bolts the surface of the section should not be smaller than 14cm² and thickness of the rod not smaller than 22mm.

Table 15. Coefficients m_2 of the utilization conditions of the structure in different conditions of humidity, in the conditions of higher temperature, of chemical aggression or working under permanent loading

conditions of utilization	coefficient m_2 1/	
1	2	3
1	structures protected against precipitation	1,0
2	structures exposed to humidity for a short time, then dried/in the open air, in factories ect./	0,85
3	structures exposed to humidity for a long time/in water, in the ground, in factories ect./	0,75
4	structures exposed to aggressive chemical conditions: - with higher aggressiveness - with strong aggressiveness	0,90 0,80
5	structures exposed to higher temperature within the range 40° - 55°C	0,80
6	structures under permanent loading	0,80 ^{2/}
7	Boarding to reinforced concrete except shores	1,25

- 1/ Coefficient m_2 may be in particular a product of values set up in table 15.
- 2/ the coefficient of the permanent loading influence is taken into account when permanent loading is higher than 80% of the total loading. Snow and wind are loads of short duration

Table 16. Corrector coefficients m_3 taking into account a kind of timber in relation to pine or spruce

kind of timber	coefficients m_3		
	tension bending compress. pressure parallel to the grain	compress. pressure across the grain	shear
larch	1,2	1,2	1,0
fir	0,8	0,8	0,8
oak	1,3	2,0	1,3
acacia	1,5	2,2	1,8
birch	1,1	1,6	1,0
beech	1,1	1,6	1,0

4.4.17. Corrector coefficients m , taking into account previous deflection of an element

Kind of stress	ratio $\frac{r}{h}$					
	125	150	175	200	250	300
compression and bending	0,7	0,8	0,9	1,0	1,0	1,0
tension	0,5	0,6	0,7	0,8	0,9	1,0

r - radius of curvature
 h - thickness of the thickest component element measured in the direction of the radius of curvature

4.4.3. Tapering of round timber in calculations should be 1 cm for 1 m

4.4.4. Weakening of section

4.4.4.1. Weakening of section with indentations must not exceed 50% of the gross section. The smallest dimension of the cross-section in places weakened with indentations should be at least 3 cm and not smaller than 0,5 of thickness with symmetric indentations and not smaller than 0,6 of thickness with asymmetric indentations.

4.4.4.2. Calculation of the section weakened with connectors F_n complies with the rules in chapter 5.

4.4.4.3. Weakening of bent sections

4.4.4.3.1. Weakening in span. Sections bent in places of the highest span moment should not be weakened with indentations through the extreme tensioned grain.

4.4.4.3.2. Weakening in the support. Depth of the undercut on a support in bent elements depends on shearing stresses and the height of elements. It should not exceed values in Table 18 and the length of the undercut should not exceed the height of an element h . Undercuts should not be applied near large lateral forces.

Table 18. Depth of the undercut on a support

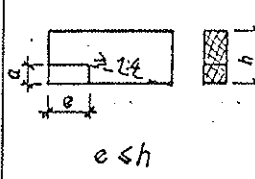
Dependence of dimensions of the undercut	Depth of the undercut	Length of the undercut
on shearing stresses	for $\frac{Q}{bh} \geq 5 \text{ kg/cm}^2$ $a < 0.1h$ for $5 > \frac{Q}{bh} \geq 3 \text{ kg/cm}^2$ $a < 0.25h$ for $\frac{Q}{bh} < 3 \text{ kg/cm}^2$ $a < 0.5h$	 <p>$e < h$</p>
on height	for $h \geq 18 \text{ cm}$ $a < 0.3h$ for $18 > h \geq 12 \text{ cm}$ $a < 0.4h$ for $h < 12 \text{ cm}$ $a < 0.5h$	

Q - lateral force on the support. The smaller value a should be adopted as depth of the undercut

4.4.4.4. Conditions for disregarding weakening. In compressed members and in the compressed zone of bent elements it is possible to disregard weakening, if a weakened place is tightly filled with timber or another material with coefficients of elasticity not smaller than for timber in the direction parallel to the grain.

4.5. System of truss members in truss girders.

Axes of truss members in truss girders should intersect in one point of the geometrical truss of a girder. It is possible to deviate from these requirements in nailed trusses or in ridge joints of other trusses. In calculations one should take into account the influence of the eccentric connection of truss members with flanges, if the intersection point projects beyond the edge of the flange (Fig.3).

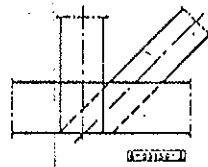

Fig.3

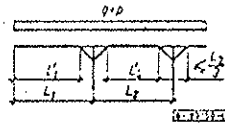

Fig.4

4.6. Tensioned truss members.

4.6.1. Stresses in axially tensioned truss members should be defined by the formula:

where:

P - calculation axial force, kg

F - net cross-section, cm^2

K_r^n - standard strength at tension - acc. to 3.11.

4.6.2. Plates for tensioned contacts should be designed for the design/calculation/load, they will bear, increased by 50%.

/8/

4.7.1. Bending

4.7.1. Theoretical span of beams. Theoretical points of support for single-span free supported beams and for end spans of multi-span beams/continuous/, if supports are constructed on bearings, should be adopted at the distance equal to 2,5% of the clear span from the support edge. For continuous beams ~~xxxxxx~~ points of support should be adopted on intermediate supports in the middle of the support. However, if the support is so wide that moments in the beam calculated as multi-span one are likely to be bigger than in a single-span free supported one, the beam should be calculated as a single-span free supported one. Points of support for beams split on supports and supported with angle braces at the distance up to 1/3 L₁ or 1/3 L₂ from the support/Fig.4/, if there is no precise statical calculation, are adopted in the intersection points of angle braces with the axis of the beam, provided that the changing design load p is not bigger than 1000KG/cm² of the beam length and the ratio of the changing design load to the permanent one g is not bigger than 2. The permanent and changing loads and the overload coefficients should be adopted acc. to PN-74/B-02009, PN-70/B-02010 and PN-70/B-02011. In case any of these conditions is not met the calculation span should be:

$$L_1 = \frac{L_1 + L_1}{2} \quad \text{or} \quad L_2 = \frac{L_2 + L_2}{2} \quad /9/$$

4.7.2. Angle braces and their connections should be checked so that stresses in them do not exceed the calculation strength.

4.7.3. Span of beams and purlins supported with bolsters on supports is adopted as equal to the axial spacing of supports.

4.7.4. Bearing reactions. Reaction on beam supports, purlins or continuous girders x is calculated as for single-span ~~xxxx~~ free supported beams. Reactions of continuous double-span beams for which the ratio of the neighbouring spans is smaller than 2/3 should be calculated according to real values.

4.7.5. Calculation of bending stresses in a solid beam is performed:

a/ with flat bending - acc. to the formula /10/

$$\sigma = \frac{M_x}{W_{xn}} \leq K_g m$$

b/ with oblique bending: - acc. to the formula /11/

$$\sigma = \frac{M_x}{W_{xn}} + \frac{M_y}{W_{yn}} \leq K_g m$$

where

M_x, M_y - bending moments from the design load, calculated in relation to the main axes of the section, kGcm,

W_{xn}, W_{yn} - indicators of net strength, cm

K_g - standard strength with bending kG/cm²

m - corrector coefficient acc. to 3.11

4.7.6. Calculation of bending stresses in a composite beam

4.7.6.1. Bending edge stress should not be bigger than K_r acc. to Table 8, and the tensioning stress, calculated in the neutral axis of a component member of a composite beam placed in the tensioned zone should not be bigger than K_r acc. to Table 8.

4.7.6.2. Calculation of bending stresses in the composite beams I, II, III/Fig.5/ with the full web, connections with nails or inserts is performed according to formulae:

$$\sigma_s = \pm \frac{M h_z J_s}{2 J_{sp} J_{sn}} \leq K_g m \quad (12)$$

$$\sigma_1 = \pm \frac{M}{J_{sp}} \left(\sigma_z e_1 \frac{F_1}{F_{1n}} \pm \frac{h_1 J_1}{2 J_{1n}} \right) \leq K_g m \quad (13)$$

$$\sigma_e = \frac{M}{J_{sp}} \sigma_z e_1 \frac{F_1}{F_{1n}} \leq K_r m \quad (14)$$

$$J_{sp} = \sum J_i + 2 \sigma_z F_1 e_1^2 \quad (15)$$

$$\sigma_z = \left[0,12 + 0,023 \frac{L}{h} - 0,00039 \left(\frac{L}{h} \right)^2 \right] k \quad (16)$$

where:

M - bending moment, kGcm

σ₃ - bending edge stress of the web, kG/cm²

σ₁, σ₄ - bending edge stress of the flange, composite beam member IV/Fig.5/, kG/cm²

σ_{e1} - bending stress in the neutral axis of the flange, kG/cm²

h - total beam height

h_g - web height, cm

h₁ - flange thickness, cm

e₁ - distance between neutral axes of the unweakened beam section and the unweakened flange section, cm

L - beam span, cm; for continuous beams in the formula 16

a respective span with the coefficient 0,8 is adopted

γ - reduction coefficient

k - coefficient depending on the kind of connectors; for nails k = 1,0; for inserts with the bearing capacity T < 2000kG - k = 2,45;

J_s, J_{sn} - moments of inertia of the web: gross, net, calculated in relation to the neutral axis of the whole beam section, cm⁴,

J_{1n}, J_{2n} - moments of the flange inertia respectively: gross, net, calculated in relation to the neutral axis of the whole beam section, cm^4 ,

J_1, J_{1n} - moments of inertia for the composite section parts in relation to their own neutral axis, parallel to the neutral axis of the whole section, gross, net cm^4

J_{sp} - moment of inertia for the whole gross section, cm^4

F_1, F_{1n} - sections, respectively: gross, net, cm^2

$K_{g,m}$ - acc. to 4.7.5.

~~XXXXXXXX~~ Moment of inertia for the net section is calculated in relation to the neutral axis of the gross section. For the section of type IV/fig. 5/

$$h_g = OJ_g = 0$$

4.7.6.3 Calculation of bending stresses of composite beams of type IV/fig.5/ connections with nails or inserts/ is performed acc. to the formula /15/ and /16/.

4.7.7. Shearing stresses at bending

4.7.7.1 Checking of shearing stresses. The shearing stress is checked in the neutral axis of the section. For sections I - IV/fig.5/ it is calculated in the axis plane $x - x$ acc. to the formula

$$\tau = \frac{Q}{b J_{sp}} (\gamma_2 S_1 + S_2) \leq K_t m \quad /17/$$

4.7.7.2 Calculation of shearing forces /delaminating/. Connectors in the seam between component parts of the bent composite beam should be calculated for the shearing/delaminating/force t_z whose value on 1cm on the whole beam width is defined according to formulae: a/ with regular spacing of connectors along the whole beam length /type I - IV/fig.5/

$$t_z = \frac{Q S_{br} \gamma_z}{J_{sp}} \quad /18/$$

b/ with regular spacing of connectors / $a_1 - b_1$ / of I-beams with a web of crossing boards

$$t_z = \frac{Q \gamma_1}{2e_1} \quad /18'/$$

c/ with the same loading of connectors on the whole beam length

$$t_{z1} = \frac{Q_1 S_{br}}{J_{br}} \quad /19/$$

In formulae 17 - 19;

Q - lateral force in the support

Q_1 - lateral variable force on the beam length, kg

Q_{xi}^{sr} - lateral medium force within the range $a_1 - b_1$, kg

S_{br} - static gross moment of the part of the section beyond the seam for a flange or a beam/fig.5/ in relation to the neutral axis of the section cm^3 ,

J_{br} - moment of inertia of the whole section, gross, cm^4

t_{z1} - shearing force, variable on the beam length, kg/cm ,

t_z - constant shearing force ab, kg/cm ,

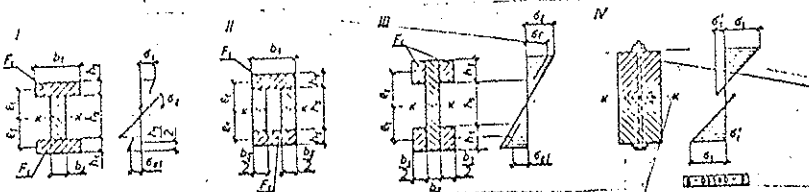

Fig. 5

PH-73/B-03150

4.7.5. Number of connectors. The number of connectors for the transfer of delaminating forces is calculated according to formulae:

a/ with regular spacing of connectors

$$n = \frac{t_{zi} l}{T} \quad /20/$$

b/ with the same loading of connectors on the whole beam span L

$$n = \frac{2}{T} \int_0^{L/2} t_{zi}(x) dx \quad /21/$$

where:

- l - beam length, cm
- T - bearing capacity of a connector in single shear, kg

4.7.6 Nailed girders. In calculations of nailed girders of I-section with the web of crossing boards or of box section/board walls/ the following rules should be followed:

- with the calculation of the section moment of inertia one does not take into account the web section/or of walls/
- one does not take into account the CO-operation of the web boards or wall boards in the transfer of shearing forces,
- boards of the web and walls are dimensioned taking into account lateral forces - formula/18/
- if order flanges have a composite section/ Fig.6/, in calculations acc. formula/15/ one should use, for the first section, closest to the neutral axis, - to the coefficient $\gamma/2$ - factor n = 1,0, for the second - factor 0,8 $\gamma/2$
- one should not design a flange section composed of more than two elements in relation to each axes /Fig.6/
- if I - beams with the web of crossing boards are composed of separately made parts/ Fig.7/, additional connectors should be calculated for the vertical force in the connection.

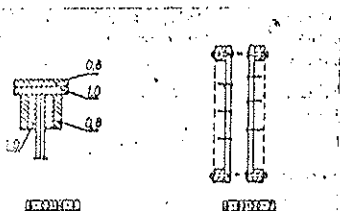

Fig. 6

Fig. 7

4.7.9. Contacts. Contact tips, plates in the contact acting for bending should have the moment of inertia at least equal to the moment of the bent bar elements and should transfer lateral forces in the contact.

4.7.10. Deflection of beams and truss girders

4.7.10.1. Deflection of beams and truss girders with flat bending. Deflection should be calculated in

compliance with structural mechanics. In the calculation

of composite beams deflection, except glued beams, to the deflection formula one should apply moment of inertia J_{sp} (comparative) according to formula/15/. Table 19 shows permissible deflections. Deflection calculations are performed from standard loads/ without overload coefficients/.

Table 19 Permissible deflections f_u of timber structures

kind of structure	Deflection f_u				
	with struct. flexion f_w		without struct. flexion f_w		
	Loading				
	perm. var.	perm. var.	perm. var.	perm. var.	
1	2	3	4	5	6
1	I-girders with a full web, box girders, composite beams	L/300	L/200	-	-
2	truss girders:				
	- approx. cal.	L/600	L/400	-	-
	- exact cal.	L/300	L/200	-	-
3	rafters, purlins ect.	-	-	-	L/200
4	panel roof elements in the period of exploitation				
	- over 15 yrs -	-	-	-	L/250
	- up to 15 yrs-	-	-	-	L/180
5	boarding lathing	-	-	-	L/150
6	beams of an unplastered floor under rooms with variable loading				
	a/ ≤ 50 kg/cm ²	-	-	-	L/200
	b/ > 50 kg/cm ²	-	-	-	L/250
7	beams of plastered floors under rooms with var. load				
	a/ ≤ 50 kg/cm ²	-	-	-	L/250
	b/ > 50 kg/cm ²	-	-	-	L/300
8	boarding of reinforced concrete struc.				
	a/ unplastered-	-	-	-	L/200
	b/ plastered -	-	-	-	L/350
9	elements of enclosing walls				
	a/ industrial buildings, tourist buildings				
	- exp. over 15 yrs	-	-	-	L/200
	- exp. up to 15 yrs	-	-	-	L/180
	b/ dwelling, office build.				
	- exp. over 15 yrs	-	-	-	L/200

Table 19. continued

- in skeleton walls and in elements
- with the length equal to the storey height - - - L/220
- in elements for a room with or without an opening - - - L/250

1/ In the approximate calculation only elastic strains of flanges are taken into account. In the exact calculation all deformations of all truss members the elasticity of all connections are taken into account.

4.7.10.2. Deflection of beams with oblique bending

Deflection of beams, bent obliquely f should be calculated according to the formula:

$$f = \sqrt{f_x^2 + f_y^2} \quad /22/$$

where: f_x, f_y - component deflections in the direction of axes, respectively x-x and y-y

4.7.10.3 The biggest permissible deflection of a timber structure calculated for the full load should not exceed values shown in Table 19. In old renovated buildings one permits deflection exceeding, by 50%, the calculated permissible deflection, assuming the elastic work of timber.

4.7.10.4. Deflection of continuous beams. In continuous beams with equal spans or when the ratio of the biggest span to the smallest one does not exceed 1:0,8 and with the same loading of all spans, or when, with equal spans, the ratio of the highest to the smallest load does not exceed 1:0,8, deflection can be approximately defined adopting the ratio of the biggest deflection of a continuous beam to the biggest deflection of a beam span/single-span free supported:

- a/ for end spans
 - 0,65 - with permanent load
 - 0,90 - with variable load
- b/ for central spans
 - 0,25 - with permanent load
 - 0,75 - with variable load

4.7.10.5. Structural deflection for special cases.

When a kind of a building requires smaller deflection than mentioned in Table 19, one has to face stricter requirements.

4.7.11. Structural flexion/in the opposite way/ Structural flexion should be:

a/ for composite beams with block connections

$$f_w \geq 1,5 f_u$$

b/ for girders with a full wall/ I - girders, box girders/ and for truss girders/without a suspended floor/

$$f_w \geq 1/200L$$

c/ for glued structures

$$f_w \geq f_u$$

- f_w - structural flexion, cm
- f_u - flexion calculated according to 4.7.10, cm,
- L - span of a beam or a truss girder, cm.

4.8. Single members, axially compressed

4.8.1. Slenderness ratio defined by the formula

$$\lambda = \frac{l}{i_{min}}$$

should not exceed values from table 20.

Table 20. Permissible slenderness ratio for compressed members

members	slenderness ratio λ	
	perm. struc.	temporary struc.
1 load-bearing columns	120	150
2 solid bars	150	200
3 composite bars on elastic connectors	175	200
4 secondary members such as: wind braces, braces, tensioned bars that can be acted on by small compression forces resulting from additional loads	200	200

While calculating slenderness ratio in mining works, for round sections one should take into account the radius of inertia for the smallest section. In other cases the radius of inertia in the middle of the buckling length of a member is adopted.

4.8.2. Buckling length l of axially compressed members is defined by the formula

$$l_x = \gamma L_x \text{ or } l_y = \gamma L_y \quad /24/$$

where:

γ - coefficient of the buckling length acc. to 4.8.3,

L_x, L_y - lengths of a member measured in the plane of main axes and equal to distances between the brace axes.

In trusses lengths of truss members L should be adopted as equal to the theoretical truss lengths of the truss.

4.8.3. Coefficients of buckling length.

- Coefficients of buckling length γ should be:
- a/ for a member fixed at one end, with the other one free - acc. to Fig. 8a/ $\gamma = 2$
 - b/ for a member /bar/ supported at both ends in a jointed way /fig. 8 b/ and in end spans of a continuous member /Fig. 8c/ with the impossibility to make lateral movements - for both cases - $\gamma = 1,0$
 - c/ for a member with one end fixed rigidly and the other end supported in a jointed way or in a similar way /Fig. 8d/ in the main plane, in which buckling is calculated, with the impossibility of lateral movements - for both cases $\gamma = 0,8$
 - d/ for truss members:
 - for truss flanges in buckling cases in the truss plane $\gamma = 0,8$
 - and out of the truss plane /Fig. 8e/ $\gamma = 1,0$
 - for stanchions and cross braces of the truss in the truss plane $\gamma = 0,8$
- when these members are connected with flanges with gains, inserts /with one bolt/ or pins $\gamma = 1,0$
- for crossing truss members /Fig. 8e/ - acc. to table 1.
 - for compressed truss flanges or transoms of frames braced with purlins, braces ect. with buckling out of the plane $\gamma = 1,0$

Table 21. Coefficients of buckling length γ for crossing truss members

members	coefficients γ	
	in the truss plane	out of the truss plane
crossing members of the truss acc. to Fig. 8e/	if the absolute value of force in the supporting member is bigger or equal to the force in the compressed member 0,50	0,60
		if the force in the supporting member is smaller than the force in the compressed member 0,80

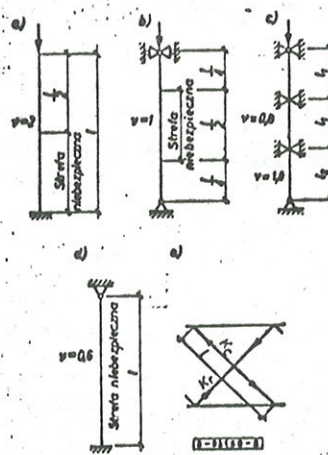

Fig. 8

4.8.4 Buckling of arches

4.8.4.1. Buckling length l in the arch plane is defined by the formula

$$l = \gamma S \quad /25/$$

where:

- γ - reduction coefficient acc. to Table 22,
- S - arch length/opened/ along the axis

Table 22. Coefficients of buckling length γ for an arch

kind of arch	symmetric load	one-sided load
three-hinged arch	0,7	0,5
two-hinged arch	0,6	0,5

PH-73/B-03150

4.8.4.2. Buckling length l out of the arch plane

- a/ For the top compressed flange the length l is equal to the distance between purlins,
- b/ for the bottom compressed flange the length l is calculated according to the formula:

$$l = \gamma L \quad /26/$$

where:

L - length of the chord between lateral bracings

γ - corrector coefficient depending on the kind of lateral bracings, that is:

- with bracings *in the form* of truss girders

$$\gamma = 1,0 \quad \text{in the form}$$

- with bracings of angle braces with one end supported on a girder, and the other one on purlins $\gamma = 1,25$

4.8.5. Buckling length of columns and transoms.

Buckling length of columns and transoms of frames and pseudoframes is defined in the following way:

- a/ if a truss girder ~~xxxxxxx~~ or a full girder is supported on columns and connected with a column with hinges /Fig. 9a/ the buckling length of the column, with buckling in the pseudoframe, is $l = 2h$. With buckling out of the pseudoframe plane l is the distance between bracings at the column height.

- b/ if a truss girder is supported on columns and is connected with a column with an angle strut bracing the angle of the pseudoframe /Fig. 9b/, then with buckling of the column in the plans of the arrangement, the buckling length may be determined by the approximate formula

$$l = 2h_d + 0,7h_g \quad /27/$$

- c/ The buckling length of symmetric columns of two- or three-hinged frames, with buckling in the frame plane may be defined by the approximate formula /Fig. 9c/

$$l = h\sqrt{4 + 1,6n} \quad /28/$$

where: n - coefficient; $n = \frac{2J_g r}{J_r h}$

J_g - moment of inertia of the column, cm^4
/for composite columns acc. to 4.9.3./

J_r - moment of inertia of the transom, cm^4
/for composite transoms acc. to 4.9.3./

h - column height, cm

r - length of the transom half /Fig. 9c/, cm

a/

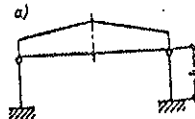

b/



c/

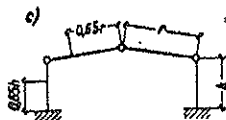

Fig. 9

4.8.6. Sections of solid axially compressed members should be checked with regard to buckling according to the formula:

$$\sigma = \frac{P}{F\beta} \leq K_c m \quad /29/$$

where:

P - design load /calculation load/

F - field of the working cross-section

with:

$F = F_n$ - if weakenings disturb the edge of a member, cm^2

$F = F_{br}$ - if weakenings do not disturb the edge of a member and are not bigger than 25% of the gross cross-section, cm^2

$F = 4/3 F_n$ - if weakenings do not disturb the edge of a member but are bigger than 25% of the gross cross-section, cm^2

β - coefficient of buckling acc. to 4.8.7.

K_c - standard strength acc. to Table 8.

PN-73/B-03150

4.9.7. Coefficients of buckling β are calculated acc. to formulae:

a/ for ratio of slenderness $0 < \lambda \leq 75$

$$\beta = 1 - 0,8 \left(\frac{\lambda}{100} \right)^2 \quad /30/$$

b/ for ratio of slenderness $75 < \lambda \leq 200$

$$\beta = \frac{3100}{\lambda^2} \quad /31/$$

Values of coefficient β are shown in Table 23

Table 23, Coefficients of buckling β for timber

λ	β	λ	β	λ	β	λ	β
5	1,00	55	0,758	105	0,281	155	0,129
10	0,99	60	0,712	110	0,256	160	0,121
15	0,98	65	0,662	115	0,234	165	0,114
20	0,97	70	0,608	120	0,215	170	0,107
25	0,95	75	0,550	125	0,198	175	0,101
30	0,93	80	0,484	130	0,183	180	0,096
35	0,90	85	0,429	135	0,170	185	0,091
40	0,87	90	0,385	140	0,158	190	0,086
45	0,84	95	0,343	145	0,147	195	0,082
50	0,80	100	0,310	150	0,138	200	0,077

For intermediate values one should interpolate linearly

4.9. Members of composite section/ axially compressed/.

4.9.1. Types of composite members sections/ compressed/. It is recommended to use composite members sections shown in figures 10 - 14 and systematized in the groups below:

I group - members composed of branches and of plates or inserts out of which only branches are fixed in joints/ Fig. 10/.

II group - members composed of abutting branches and fixed to supports

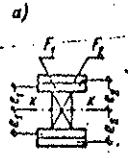

a/

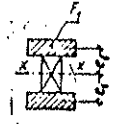

b/

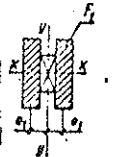

c/

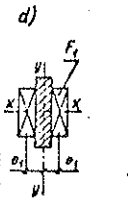

d/

Fig. 10

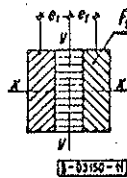

Fig. 11

III group - members composed of branches with clear spacing up to 3 thicknesses of the branch with batten plates of axial spacing not bigger than $1/3 \cdot l$ /Fig.12/ where l - length of a member,

IV group - composite trussed members of big spacing, bigger than 6 thicknesses of the branch /Fig.13/ with nailed connections.

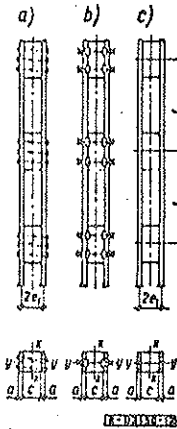

Fig. 12

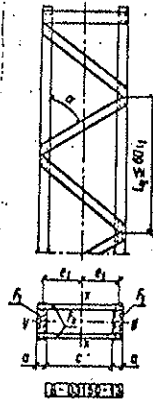

Fig. 13

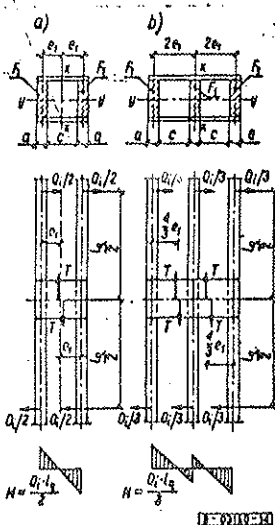

Fig. 14

4.9.2. Number of parallel seams both to the axis $x - x$ and to $y - y$ cannot exceed 4 in the cross-section /Fig.10a/

4.9.3 Buckling in the plane perpendicular to seams. The checked moment of inertia J_{sp} or axis the checked ratio of slenderness λ_{sp} of the composite member section working for buckling in the plane perpendicular to seams is calculated according to formulae:

a/ group I /Fig. 10a/

$$J_{sp} = \sum J_i + 2\gamma_1' F_1 e_1^2 + 2\gamma_2' F_2 e_2^2 \frac{S_2}{S_1} \quad /32/$$

for elements such as in fig. 10b/, c/ and d/ $F_2 = 0$ and the formula /32/ is reduced to

$$J_{sp} = \sum J_i + 2\gamma_1' F_1 e_1^2 \quad /32'/$$

b/ group II /Fig.11/

$$J_{sp} = \sum J_i + 2\gamma_1'' F_1 e_1^2 \quad /33/$$

c/ group III /Fig.12/

$$J_{sp} = \sum J_i + 2\gamma_2' F_2 e_1^2 \quad /34/$$

d/ group IV /Fig.13/

$$J_{sp} = \sum J_i + 2\gamma_2'' F_2 e_1^2 \quad /35/$$

e/ group V /Fig.14/

$$\lambda_{sp} = \sqrt{\lambda_j^2 + k \frac{n_0}{2} \lambda_2^2} \quad /36/$$

where:

γ_1' - reduction coefficient

$$\gamma_1' = 0.04 + 0.005 \lambda_j; \quad /37/$$

for nails: $\gamma_1' = \gamma_1''; \gamma_1'' = 1.3 \gamma_1'$

γ_2' - reduction coefficient

$$\gamma_2' = 0.018 + 0.00545 \lambda_j$$

$$\gamma_2'' = \gamma_2' a; \gamma_2'' = 0.25 \gamma_2' a \quad /38/$$

a - corrector coefficient depends on the kind of connectors:

a/ for nails $a = 1,0$

b/ for inserts $a = 1,05$

c/ for pins $a = 0,85$

$\sum J_i$ - moment of inertia of all components of a composite member in relation to their own axes, parallel to the seam, cm^4

F_1, F_2 - field of element section respectively beyond the first and the second seam counting from the neutral axis of the section/fig.10/, cm^2

e_1, e_2 - distances between the axis running through the centre of gravity of F_1 or F_2 sections and the neutral axis of the whole section, cm .

S_1, S_2 - static moment of F_1 or F_2 in relation to the neutral axis of the whole section, cm^3 .

λ_j - ratio of slenderness of the solid member with the same cross-section as in the composite member

$$\lambda_j = \frac{l}{i_j} \quad /39/$$

i_j - radius of inertia if the composite member calculated as the solid one, cm .

$$i_j = \sqrt{\frac{J_j}{\sum F_i}} \quad /40/$$

J_j - moment of inertia of the whole composite section/branches, plates, inserts/ in relation to the main axis of this section, cm^4

i_{sp} - radius of inertia, cm

$$i_{sp} = \sqrt{\frac{J_{sp}}{\sum F_i}} \quad /41/$$

λ_{sp} - ratio of slenderness of a composite member for members of groups I - IV

$$\lambda_{sp} = \frac{l}{i_{sp}} \quad /42/$$

λ'_{sp} - ratio of slenderness of a composite member of group V

k - coefficient depending on the kind of connectors to connect external batten plates with branches /Fig.14/, for glued connections $k = 3,0$; for nailed connections $k = 4,5$

n_0 - number of branches in a member

λ_η - ratio of slenderness of the thinnest branch of the composite member in relation to its own axis $\eta - \eta$ parallel to the seam

$$\lambda_\eta = \frac{l_\eta}{i_\eta} \quad /43/$$

i_η - radius of inertia of the thinnest branch, cm

For members from groups III - IV l_η measured between the axes of batten plates or joints should not be bigger than 1/3 of the member length, and the branch ratio of slenderness in the formula/43/ should meet the conditions $\lambda_\eta \leq 60$. If composite members of groups II - IV have a bigger number of branches than in Fig. 11 - 13, then the formulae 33 - 35 should be complemented by

$$2 \gamma_1 \frac{S_2}{S_1} F_2 \theta_2^2 \quad /44/$$

4.9.4. Buckling in the plane parallel to the seams

Moment of inertia J_{sp} of the composite member section working for buckling in the plane parallel to seams is calculated according to the formula

$$J_{sp} = \sum J_{g_i} + 0.8 \left(\sum J_{n_j} + \sum J_{wk} \right) \quad /45/$$

where: J_{g_i} - moment of inertia of a branch, cm^4

J_{n_j} - moment of inertia of a batten plate, cm^4

J_{wk} - moment of inertia of an insert, cm^4

4.9.5. Moment of inertia of glued members.

Glued members composed of several parts may be calculated as members with uniform section while meeting the conditions from 6.1.

4.9.6. Moment of inertia of columns and frame-triangoms with variable sections on the length may be assumed as constant taking as a basis the cross-section at the distance $0,65h$ or $0,65r$ from the supporting hinge or the ridge hinge/fig.9c/.

4.9.7. Calculation of shearing forces/delaminating/. To ensure the cooperation of elements in a composite member, the number of connectors should be calculated for shearing/delaminating/ forces. The shearing force t_w per 1 cm of the member on its whole width is calculated for members of groups I and II according the formula

$$t_w = \frac{Q S_{br} \gamma}{J_{sp}} \quad /46/$$

where:

Q - substituting lateral force with buckling

$$Q = \frac{P}{80\beta} (1+x) \quad /47/$$

S_{br} - gross static moment of the section part beyond the seam cm^3

J_{sp} - gross moment of inertia, cm^4

x - coefficient the value of which should be:

- for bar elements/members/ of groups I - III as in Fig. 10 - 12 $x = 0$

- for elements with external batten plates of group IV/fig. 14/ or trussed ones of group V/fig.13/

a/ with $2e = 20i_g$ $x = 0$ (48)

b/ with $2e > 20i_g$ $x = 0,05 \left(\frac{2e}{i_g} - 20 \right)$

γ - reduction coefficient depending on m a kind of member and connectors equal to $\gamma_1, \gamma_2, \gamma_3$

γ_2 acc. to 4.9.3,

β - coefficient of buckling depending on m the ratio of slenderness of a member

P - axial force in a member/bar/ from design loads, kg .

4.9.8. External batten plates should be calculated for a shearing force per one batten P , tes:
 a/ with two branches/FIG.12 and 14a/

$$T_1 = \frac{Ql_1}{2e_1} \quad /49/$$

b/ with three branches/FIG.14b/

$$T_2 = 0,5 \frac{Ql_2}{2e_1} \quad /50/$$

where $2e_1$ - distance between branch centres /Fig. 14 a, b/

Apart from that, batten plates should be calculated for the moment of shearing forces in relation to the fixing of a batten plate to a branch/FIG.14/:

a/ with two branches $M = \frac{Ql_1}{2} \quad /51/$

b/ with three branches $M = \frac{Ql_2}{3} \quad /52/$

In columns with inserts for the branch spacing

$\frac{c}{a} \ll 2$ one does not take into account the moment from shearing forces.

4.9.9. Cross braces in trussed members of type IV /Fig.13/ are calculated according to the formula

$$K = \frac{Q}{\gamma \sin \alpha} \quad /53/$$

where: Q - lateral force acc. to formula /47/, kG

$$\gamma = 1 - \frac{P\lambda_{sp}^2}{3100 K_c F_{br}} \leq 1,0 \quad /53'/$$

where:

P - calculation compressing force, kG
 λ_{sp} - ratio of slenderness of a member.

4.9.10 Minimum number of connectors in the column connection. In column connections/type III, Fig.12/ there should be at least 4 nails, 2 bolts or 2 rings. Glued inserts should have the length equal at least to double spacing of columns. Trussed members of type IV/FIG.13/ should have batten plates at both ends and in every connection of a cross-brace with branches/on each side/ at last 4 nails.

4.10. Members, loaded eccentrically.

4.10.1. Eccentrically tensioned members. Stresses in a dangerous section are calculated according to the formula

$$\sigma = \frac{P}{F_n} + \left(\frac{M_x}{W_{xn}} + \frac{M_y}{W_{yn}} \right) \frac{K_c}{K_g} \leq K_r m \quad /54/$$

with symbols as in 4.7.5.

4.10.2. Eccentrically compressed members acc. to Fig. 10,12 and 14 are calculated according to the formula

$$\sigma = \frac{P}{F_n} + \left(\frac{M_x}{W_{xn}} + \frac{M_y}{W_{yn}} \right) \frac{K_c}{K_g} \leq K_c m \quad /55/$$

$$\sigma = \frac{P}{F\beta} + \left(\frac{M_x}{W_x} + \frac{M_y}{W_y} \right) \frac{K_c}{K_g} \leq K_c m \quad /56/$$

For composite members with batten plates it is necessary to check stresses in end branches between ba-

ttten plates according to the formula

$$\sigma = \frac{P}{F_n \beta_n} + \left(\frac{M_x}{W_x} + \frac{M_y}{W_y} \right) \frac{K_c}{K_g} \cdot \frac{1}{\beta_n} \leq K_c m \quad /56'/$$

Composite trussed members/FIG.13/ are calculated according to the formula

a/ for the whole composite section

$$\sigma = \frac{P}{F_n} + \frac{M}{2F_n e_1} \leq K_c m \quad /55''/$$

b/ for branches between truss joints

$$\sigma = \frac{P}{F_n \beta_n} + \frac{M}{2F_n e_1 \beta_n} \leq K_c m \quad /56''/$$

where:

β_n - coefficient of buckling of a branch with the buckling length l_n /smaller of the two directions of buckling/

β - the smallest coefficient of buckling from two directions for the whole member

W_x, W_y, W_{xn}, W_{yn} - moduli of gross strength, net of the solid section/FIG.12 and 14/ cm^3

4.10.3. Number of n of connectors between branches of a composite, eccentrically compressed member is defined by the formula:

$$n = \frac{t_2 l}{T \gamma} \quad /57/$$

where:

- t_2 - shearing/delaminating force/ acc. to the formula/18/, kG/cm,
- l - length of a member, cm
- T - load-bearing capacity of a connector
- γ - coefficient taking into account the additional moment from the shearing force acc. to the formula /53''/.

4.11. Bracing

4.11.1. Lateral bracing for diminishing the buckling length of a column or a compressed flange of a flat structure is calculated for a shearing force according to the formula:

$$P = \frac{N}{50} \quad /58/$$

and members which support compressed flanges of a few structures/flat/ or columns should be calculated for compressing forces in separate zones acc. to the formula/FIG.15/

$$P = \frac{nN}{50} \quad /59/$$

where:

- N - the biggest compressing force in the flange of a girder or a column, kG
- n - number of columns or flat structures/FIG.15/

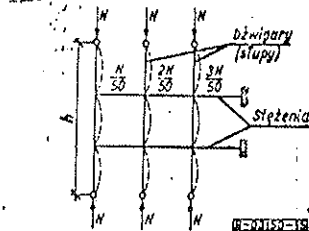

Fig. 15

4.11.2. Trusses and braces/for bracing/, the task

of which is to diminish the buckling length of flanges of flat compressed girders, arches and frames, may be approximately calculated for forces operating perpendicularly to these structures, the forces resulting from the substitute load q distributed in a uniform way along the flange/ Fig. 16/ according to the formula

$$q = 0.08 \frac{N}{l_1} \quad /60/$$

and loading of a joint - according to the formula:

a/ for the case as in Fig. 16a/, b//for braces/

$$Q = 0.08 \frac{N_e}{l_1} n \quad /61/$$

b/ for the case as in Fig. 16c/, d/, e//for trusses/

$$Q = 0.08 \frac{N \cdot a}{l_1} n \quad /62/$$

where:

- N - the biggest calculation force in the compressed flange of a girder, KG,
- l_1 - buckling length of the whole flange of a compressed girder/ Fig. 16/, cm
- a - length of a ^{bracing} truss section
- e - buckling length of a flange of a flat load-bearing structure on the distance between braces/ Fig. 16a/, cm
- n - number of flat structures transferring forces from the flange buckling to one truss or brace.

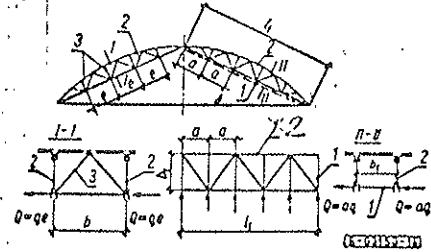

Fig. 16

- 1-bracing truss between girders,
- 2-girder
- 3-brace

4.11.3. Stress checking in the compressed flange of a girder. Checking is not necessary for cases when distances between bracings are not longer than 40 i.

4.12. Structural height of girders.

4.12.1. Structural height H of I- or box beams with a web or a wall of crossing boards or plywood should be measured between external edges of flanges. For beams with parallel flanges or the upper shed flange, the height is measured in the middle of the span and for beams with upper ridge flange - in 1/4 of the span, assuming $H = 1/8 \div 1/11 L$.

4.12.2. Structural height H of truss girders measured between flange axes in the middle of the span, if one does not perform an exact calculation of deflections following the rules of building mechanics, should be defined in the following way:

- a/ for girders with the upper arch flange - $H_0 = 1/7 \div 1/8 L$,
- b/ for girders with parallel flanges or bent ones - $H_0 = 1/6 \div 1/7 L$.
- c/ for triangular girders - $H_0 = 1/5 \div 1/7 L$.

4.12.3. Elevation f and structural height h of the cross-section of a two- or three-hinged arch and of a flat roof should not be smaller than:

a/ for centre arch of short boards on edge / Fig. 18/

$$f \geq 1/6 L \quad h \geq 1/80 L$$

b/ for a two-hinge arch of I-section with a latticed wall or full wall/ Fig. 17 b/

$$f = 1/7 \div 1/8 L \quad h = 1/30 L$$

c/ for three-hinge arches with full or latticed segmented elements/ Fig. 17 a/

$$- \text{flat } f = 1/6 \div 1/7 L \quad h = 1/15 \div 1/25 L$$

$$- \text{spiry } f = \text{according to building requirements } h = 1/15 \div 1/30$$

d/ for lamella roof/ Fig. 17c/

$$f = 1/7 L \quad h = 1/100 L$$

where:

- n_1 - number of connectors at the ends of centrings
- n_2 - number of connectors on the length l_1 of a centring
- T - bearing capacity of one connector, kG
- M_1 - the biggest moment on the length of a successive short board according to the diagram on Fig. 18c/ for a strengthened axis of a short board/, kGcm,
- a - distance between the centre of gravity of connectors placed at the end of a short board and the place of the biggest moment, cm
- l_1 - length of a successive short board, cm,

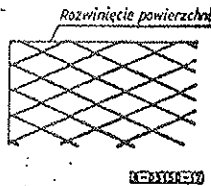
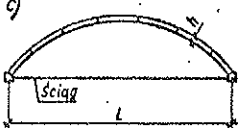
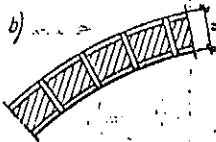
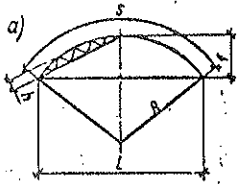

Fig. 17

4.13. Centrings

4.13.1. Measuring of centrings is checked with regard to bending in their plane, taking into account the axial compressing force working in them according to 4.10.2. with the following symbols:

$F = F_n$ - section of all short boards, not sheared in the contact, cm²

$W = W_n$ - modulus of net strength of short boards, not sheared in the contact, cm

Length of short boards should not be smaller than the tenfold biggest cross-section of a short board and not smaller than 1,20 m.

4.13.2. Number of connectors in centrings of the type shown in Fig. 18 is defined by the formula

a/ with connectors at the ends of short boards/ Fig. 18a/

$$n_1 = \frac{M_1}{Ta} \quad /63/$$

b/ When connectors are placed on the whole length of a short board / Fig. 18b/

$$n_2 = \frac{24 M_1}{Tl_1} \quad /64/$$

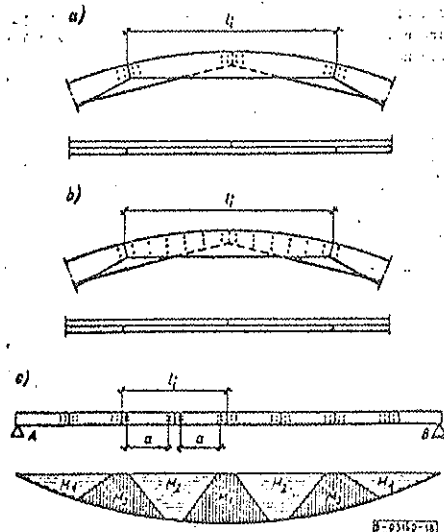

Fig. 18

5. CONNECTIONS

5.1. Nailed connections. For connections it is necessary to use round nails according to BH-70/5028-18 and square twisted nails according to BH-70/5028-19 with diameters from 1/5 to 1/11 of the thinnest of the connected elements.

5.1.2. Minimum thickness of boards and steel sheets used in timber nailed structures.

5.1.2.1. Minimum thickness δ of boards should not be smaller than

$$\delta = d(3 + 8d) \geq 2.2 \text{ cm} \quad /65/$$

with the exception of:

a/ web boards of nailed beams of I-section/ Fig. 6/ whose thickness should not be smaller than 16mm,

b/ component boards of composite elements connected with nails driven into previously drilled holes, with the board thickness not smaller than $6d$. With thinner boards the bearing capacity is decreased according to 5.1.7.3.

5.1.2.2. Minimum thickness of steel sheets used in joints and contacts should not be smaller than 2mm.

5.1.2.3. Nails in connections timber - plywood should have, with the plywood thickness 8mm - the diameter to 4,0mm and with thicker plywood - the diameter up to 4,5mm.

5.1.3. Drilling of holes for nails. Nails in connections of hardwood should be driven in previously drilled holes for the whole nail length. Drilling of holes for nails in softwood is not necessary/p.5.1.7.1./ The diameter of drilled holes should be

$$d_0 = 0.95 d_{gn} \quad /66/$$

5.1.4. Arrangements of driven nails. Nails are driven according to one of the three arrangements: a/ rectangular/ Fig. 19a/, b/ staggered/ Fig. 19b/, c/ at the angle to the direction of the grain/ Fig. 19c/

In the arrangement of nails there are rows and series. Series run along the direction of the grain, rows across or at the angle to the direction of the grain. Distance S from the board or the plank front in the three arrangements, for tensioned elements should not be smaller than $15d$, and for compressed elements - not smaller than $10d$. Distance between nail centres in series S_1 depends on the ratio of the thinnest element thickness to the nail diameter and is defined by the diagram in Fig. 20. For nails driven into previously drilled holes distances S_1 may be diminished to $10d$. Distance S_2 of the first nail series to the unloaded edge of an element should not be smaller than $4d$. Distance S_3 between series of nails in the rectangular arrangement and at the angle/with the angle $\alpha > 45^\circ$ should not be smaller than $4d$ / Fig. 19a, c/ and in the staggered arrangement and at the angle/with the angle $\alpha < 45^\circ$ / - not smaller than $3d$ / Fig. 19b, c/.

In connections at the angle it is necessary to keep minimum distances between nails along and across the direction of the grain of connected elements/ Fig. 21/

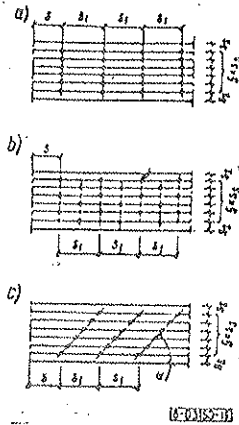

Fig. 19

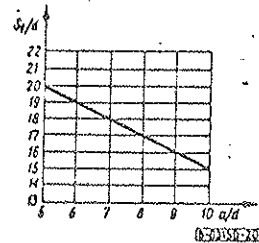

Fig. 20

Distance between nails in one series S_1 including assembly nails should not be longer than $40d$ and S_3 not longer than $20d$. Only in continuous roof purlins assembly nails can be placed at the distance up to 50cm.

5.1.5. Nail driving.

In general nails should be driven on both sides of an element, so that their ends do not stick out. When the nail end projects beyond the surface of an element, one should take into account weakening of the section in this place $1,5d$ and clench the nail ends/ Fig. 22/ along the direction of the grain.

- in boarding elements for reinforced concrete such as shackles, pressure boards ect. taking lateral pressure of concrete mass - $j = 1,8$
- in all other cases - $j = 1,0$

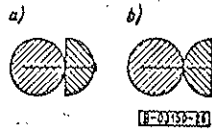

Fig. 26

Table 24. Load-bearing capacity T of nails driven into pine wood and spruce wood directly or into previously drilled holes /single shear/

size of nails	sawn timber with thickness of at least	Driving depth s mm at least /without a nail point/				Bearing capacity kg	
		directly	into drilled holes	single shear	multi shear	directly into drilled holes	
2,8 x 65	22	22	34	22,5	37	46	
3,0 x 70	22	22	36	24	43,5	54,5	
3,0 x 80	22	22	36	24	43,5	54,5	
3,5 x 90	22	22	42	28	57	70	
4,0 x 100	25	25	48	32	72	90	
4,0 x 110	25	25	48	32	72	90	
4,5 x 125	30	28	54	36	87,5	109	
5,0 x 150	35	32	60	40	103,5	129	
5,5 x 150	40	35	66	44	122	153	
6,0 x 175	50	35	72	48	140	175	
7,0 x 200	60	45	84	56	180	225	
7,0 x 225	60	45	84	56	180	225	
8,0 x 250	75	50	96	64	222	278	
9,0 x 275	90	55	108	72	266	332	
9,0 x 300	90	55	108	72	266	332	

5.1.7.2. The influence of nail driving depth s on the nail bearing capacity. Load-bearing capacity of a nail according the formulae/67 & 69/ can be noted, when the nail driving depth s/without a nail point/ in the last connected element is: for nails in single shear - 12s, for nails in multi shear - 8s. With the nail driving length s, shorter than the one mentioned above/fig.23b/, c/, d/ the nail bearing capacity decreases in relation to the basic one:

a/ for nails in single shear - $T' = T_0 \frac{s_0}{12s}$ /70/

b/ for nails in multi shear - $T' = T_0 \frac{s_0}{8s}$ /71/

where $T_0 = T_1$ or T_2 - according to the formulae /67 & 69/.

One does not take into consideration the work of the nail end in a connection, if the nail driving depth s smaller than 6d for nails in single shear and 4d for nails in multi shear.

5.1.7.3. Load-bearing capacity of nails driven into drilled holes with the diameter $d > 4,5 \text{ mm}$, is calculated according the formulae/68 and 69/ when the thickness of an element $b > 6d$. For thinner elements the nail load-bearing capacity decreases

$$T' = 1,25 T_0 \frac{d}{6d} \quad /72/$$

5.1.7.4. Load-bearing capacity of nails in connections timber-steel sheet/fig.24/ with holes/drilled simultaneously/ is calculated for single shear according the formulae /68/ and /69/ if the

the nail anchorage length s is not smaller than 14d/without a nail point/

While defining load-bearing capacity in connections with plywood batten plates, it is necessary to check the pressure/walls of the holes for nails in plywood according the formula

$$T = \sigma d k_{sk}^d m \quad /73/$$

where k_{sk}^d - standard stress of pressure in plywood, kg/cm²

In tensioned contacts with the number of nails in a series $10 \leq 20$, their number should be increased by 10%; with the number of nails bigger than 20 by 20%.

5.1.8. Length of nails. While calculating the length of nails one should take into account the required nail driving depth adding 1,0cm for every seam between connected elements and 1,5d for a nail point/fig.22/.

5.1.9. Permissible radius of curvature of elements in nail connections.

While connecting curved elements with nails, the radius of these elements should be $r > 300b/b$ - thickness of the thickest element/.

5.1.10. Calculation of the net cross-section. In tensioned elements in nail connections, the section is diminished by holes for nails with the diameter bigger than 4,5mm:

- with the rectangular arrangement or at an angle all holes are in one row
- with the staggered arrangement all holes are in two rows

While driving nails into drilled holes we take into account the section weakening for every diameter of driven nails.

PN-73/B-03150

5.1.11. Pulled out nails. Load-bearing capacity of nails,

R/RG , while pulled out, is calculated according to the formulae:

- for dry hardwood/up to 20% - $T = 15dlm$ (74)
- for wet hardwood/above 20% - $T = 6 dlm$ (75)

where:

- l - nail working length according to Fig.27/cm/ should not be smaller than twofold thickness of a nailed element/ without a nail point - $1,5d$
- d - nail diameter, cm; for diameters exceeding 0,5cm d should be $d = 0,5cm$

Load bearing capacity of pulled out nails is taken into account only:

- in boardings/ Fig.27a, c/ and in elements of rafter framing/battens, rafters, purlins ect./
- in connections of structural elements, in which nails work for bending and pulling/ Fig.27b/

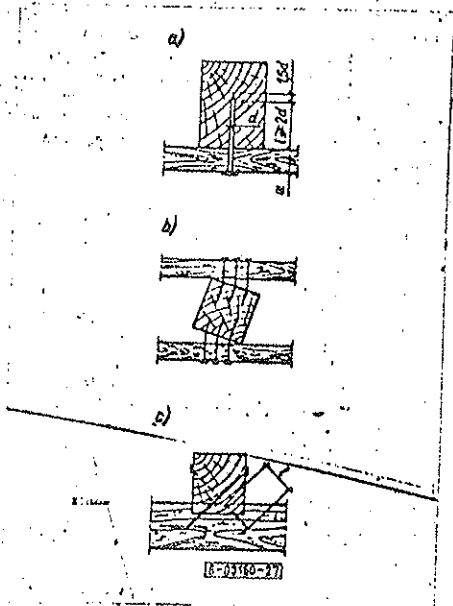

Fig. 27

Load bearing capacity should not be taken into account with pulling out nails, driven ~~previously~~ into previously drilled holes or into the face of an element and in case when dynamic loads are likely to occur.

5.2. Bolt and screw connections

5.2.1. Bolts should be made of cold rolled steel acc. to PN-75/M-93200.00. The bolt diameter should be 10 ÷ 24 mm and correspond with the assortments of standard nuts acc. to 2.4.1.2 and table 25.

5.2.2. Screws should be applied acc. to 2.4.1.1. The smallest permissible diameter of screws used in connections between elements with the thickness up to 8cm is 10mm and with thicker elements - 12 mm.

Table 25. Bolts, nuts and washers in timber structures

bolts, round steel bars acc. to PN-75/M-93200.02	10	12	14	16	18	20	22	24
hexagon rough nuts acc. to PN-75/M-82144	-	M-12	-	M-16	-	M-20	-	M-24
hexagon nuts of medium accuracy and accurate acc to PN-75/M-82144	M-10/	M-12	M-14/	M-16	M-18/	M-20	M-22/	M-24
square nuts acc. to PN-75/M-82151	-	M-12	-	M-16	-	M-20	-	-
square washers in timber structures acc. to PN-59/M-82010	/12/	14/	/16/	18	/20/	22	/24/	26

Bolt diameter adopted on the basis of calculations should correspond to the diameter of standard nuts. Dimensions in brackets should be avoided.

5.2.3 Arrangements of bolts and screws. Bolts and screws are arranged ~~as follows~~ in two arrangements: perpendicular as in Fig. 19a/ and staggered as in Fig. 19b/. Distance S between the centre of the first bolt and the face of an element should be:
 a/ in tensioned elements $S \geq 7d$
 b/ in compressed elements $S \geq 4d$
 Spaces between bolts in series $S_1 \geq 7d$. Distance between the first series of bolts and the unloaded end of an element $S_2 \geq 3d$.
 Distance S_3 between both in the perpendicular scheme and the staggered one $S_3 \geq 3.5d$.
 As regards screws, distances should be determined in such a way so as to make it possible to tighten up nuts with with a spanner.

5.2.5. Number of bracing screws in contacts. In tensioned contacts with timber plate, at least 25% of bolts should be replaced with screws of the same diameter while in contacts with steel plates - at least 50%. In cases each side of a contact/tensioned/ should have at least three screws/2 at nut ends and one at the contact/. A threaded part of a screw should not be let into timber.

On each side of compressed contact one should place at least 2 screws.

5.2.4. Number of bolts in tensioned contacts on each side should be at least 2 in series and two in rows/ Fig. 25a/.

5.2.6. Number of bolts in joints of truss girders should be at least 2 including at least 1 bracing screw. Bolts should be placed symmetrically to the axis of a member

5.2.7. Steel washers to be placed under a screw head and nuts acc. to Table 25 should be used in timber connections without steel cover plates.

5.2.8. Bolt and screw connections can be applied in structures, if measures are taken to protect these structures against too big deformation/structural flexion and proper fitting of bolts in timber holes - p. 5.2.10.

5.2.9. Bracing screws should have washers under heads acc. to PN-59/M-32010. Dimensions of washers are to be found in Table 25.

5.2.10. Seating of bolts and screws in connections should be in holes with the diameter of about 0,97 of the bolt or screw diameter.

5.2.11. Load bearing capacity of a bolt or a screw single shear. Bolt or screw connections may be in single or multi shear. Force T/kg/ carried by one bolt shear in a hardwood connection, with the force operating along the grain, is calculated according to the following formulae, assuming the least of the obtained values:

a/ as regards pressure $T = K_{d\alpha} a_1 d m$ (176/)
 b/ as regards bending $T = A d^2 m$ (177/)

- where:
- $K_{d\alpha}$ - design strength at pressure in the hole of an element acc. to Table 26, kg/cm²
 - d - bolt diameter, cm
 - a_1 - thickness of a timber element/ in asymmetrical connections - thinner element/
 - A - coefficient/ acc. to Table 26/, kg/cm².
 - m - corrector coefficient acc. to 3.11.

Values T/for m = 1/ are shown in Table 27.

Table 26. Design coefficients $K_{d\alpha}$ with $\alpha = 0^\circ$ and coefficients A

Type of connection	Element	Bolt and Screw connections	
		$K_{d\alpha}$ kg	A
Asymmetrical 	thinner	55	210
Symmetrical 	central	50	240
	end	70	325

Table 27. Design load bearing capacities of steel bolts and screws in single shear/kG/ in symmetrical T_a and T_c and asymmetrical T_n connections

bolt diameters	design values	thickness of elements, mm																				
		19	22	25	29	32	35	38	42	45	50	57	60	63	70	76	79	89	100	120	140 and more	
10	T_a	133	154	175	203	224	245	266	294	315	325	325										
	T_c	95	110	125	145	160	175	190	210	225	240	240										
	T_n	104	121	147	159	175	192	204	200	210	210	210										
12	T_a	160	185	210	244	268	294	319	353	378	420	468	468	468								
	T_c	114	132	150	174	192	210	228	252	270	300	342	345	345								
	T_n	125	145	165	191	211	231	251	277	297	302	302	302	302								
14	T_a	186	216	245	284	314	343	372	411	440	490	558	588	617	637	637						
	T_c	133	154	175	203	224	245	266	294	315	350	400	420	440	470	470						
	T_n	146	169	193	223	247	270	293	324	347	386	411	411	411	411	411						
16	T_a	213	246	280	325	358	392	425	470	504	560	638	672	705	784	832	832	832				
	T_c	152	176	200	232	256	280	304	336	360	400	456	480	504	560	607	614	614				
	T_n	167	193	220	255	281	308	334	369	396	440	502	527	537	537	537	537	537				
18	T_a	239	277	315	366	403	440	479	530	567	630	718	756	794	882	957	995	1050	1050			
	T_c	171	198	225	261	288	315	342	378	405	450	513	540	567	630	684	710	780	780			
	T_n	188	218	248	287	317	347	376	416	445	495	565	595	625	680	680	680	680	680			
20	T_a	266	308	350	406	448	490	532	588	630	700	798	840	882	980	1060	1100	1245	1300	1300		
	T_c	190	220	250	290	320	350	380	420	450	500	570	600	630	700	760	790	890	960	960		
	T_n	209	242	275	320	352	386	418	465	496	551	628	660	694	772	837	840	840	840	840		
22	T_a	292	338	385	447	493	539	585	647	693	770	877	923	970	1080	1170	1215	1370	1540	1575	1575	
	T_c	209	242	275	319	352	385	418	462	495	550	627	660	693	770	836	870	980	1100	1160	1160	
	T_n	230	266	302	351	387	423	460	508	545	606	690	726	763	846	920	957	1000	1000	1000	1000	
24	T_a	319	369	420	487	537	588	638	705	756	840	957	1020	1060	1175	1275	1330	1490	1680	1870	1870	
	T_c	250	290	330	383	422	462	501	553	594	660	752	790	830	923	1000	1040	1170	1210	1210	1210	
	T_n	228	264	300	348	384	420	456	504	540	600	685	720	755	840	912	947	1070	1200	1320	1380	

5.2.12. Load bearing capacity of screws at tensioning /80/ is calculated according to the formula

$$T = \frac{\pi d_r^2 K_r}{4} \quad /78/$$

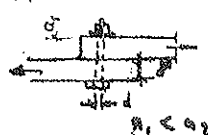
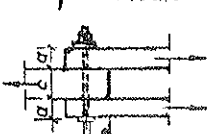
where:

- d_r - diameter of the core of the threaded part, cm
- K_r - tensioning strength of screws acc. to PN-76/B-03200, kg/cm²

5.2.13. Load bearing capacity of bolts with the force working perpendicularly to the grain. Force T, kg, transferred safely by a single shear of a bolt or a screw is calculated according to the formulae /76/ and /77/ with the coefficient 0,7.

With the force working at an acute angle to the direction of the grain the value of the corrector coefficient is determined on the basis of linear interpolation.

5.2.14. Load bearing capacity of bolts or screws in connections timber - steel sheet is defined acc. to the formula /76/ or /77/ with the coefficient 1,25. In connections timber - plywood with bolt connectors one should check the pressure in the plywood hole for bolts acc. to the formula

$$T = 0,8 \delta d K_c m \quad /79/$$

where

- δ = thickness of plywood, cm
- d - diameter of a bolt or a screw, cm
- K_c - acc. to Table 12

5.2.15. Calculation of net cross-section. In bolt connections one should take into account the section weakening for a rectangular arrangement - with all holes in one row and for a staggered arrangement with all holes in two rows, if distance between them does not exceed 20 cm or with holes in one row when distance between neighbouring rows exceeds 20 cm.

5.3. Connections with timber screws

5.3.1. Types of screws. In timber structures one should use:

- a/ screws for spanner - square head or hexagon head screws acc. to PN-72/M-82501 and PN-72/M-82502 /Fig. 28d/,
 - b/ screws for a screw-driver - acc. to PN-72/M-82503, PN-82503, PN-72/M-82504, PN-72/M-82505 and PN-72/M-8209/ Fig. 28c/
- Minimum diameter of screws should be 4 mm.

5.3.2. Fixing of timber screws. Screws should be seated in drilled holes with the diameter of about 2 mm smaller than the screw diameter d. Reaming should be done on the length of about 0,80 l of a screw /Fig. 28 a, b/.

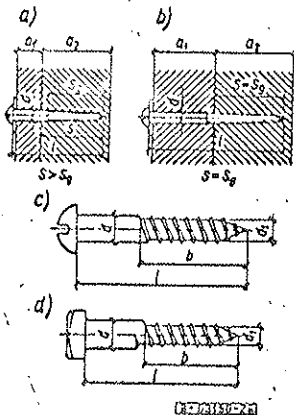

FIG. 28

5.3.3. Timber screws working for bending and pressure.

Connections with timber screws are made as single shear. To determine load bearing capacity of screws in single shear with the force working along the grain the smaller value /kg/ from the formulae is assumed:

$$T = 50 a_1 d m \quad /80/$$

$$T = 210 d^2 m \quad /81/$$

where:

- a_1 - thickness of a board or plywood fastened to a thicker element /Fig. 28a/, cm
- d - screw diameter, cm

In timber connections with metal cover plates load bearing capacity is defined by the formula:

$$T = 1,25 \cdot 210 d^2 m \quad /82/$$

For screws with the diameter $d > 10$ mm, with the force working perpendicularly to the direction of the grain, while defining load bearing capacity one should use, additionally, the coefficient 0,7. With the force working at an acute angle to the direction of the grain, intermediate values of coefficients are determined according to linear interpolation.

Load bearing capacity of screws, defined according to the formulae /80/ and /81/ refers to the basic depth of screwing in $s = 8d$. With the screwing depth $4d < s < 8d$ load bearing capacity of a screw diminishes in relation to the basic one and is calculated according to the formula

$$T_s = T \frac{s_0}{8d} \quad /83/$$

The work of screws screwed in less deeply than $4d$ and of screws seated along the grain is not taken into account. With screwing depth exceeding $8d$, calculations take into account only $s = 8d$.

5.3.4. Arrangements of screws. Screws should be arranged as nails, with minimum spacing:

- for timber elements and plywood

$$S = S_1 \geq 10d$$

$$S_2 = S_3 \geq 3d$$

= for metal plates

$$S = S_1 \geq 5d$$

$$S_2 = S_3 \geq 2,5d$$

Besides, with screws for a spanner, spacing should be such so as to facilitate screwing home with a spanner.

5.3.5. Minimum number of screws in a connection. In screwed connections the minimum number of screws should be 4 - for screws with the diameter $d \leq 10$ mm and 2 - for screws with the diameter $d > 10$ mm.

5.3.6. calculation of net cross-section acc. to 5.2.15.

5.3.7. Timber screws working for pulling

5.3.7.1. Arrangement of screws. Screws are arranged in the rectangular and staggered arrangement/Fig.19a,b/ with spacing:

$$S = S_1 \geq 10d, S_2 = S_3 \geq 5d$$

5.3.7.2. Load bearing capacity of screws at pulling.

Pulling load bearing capacity T_w /kG/ of a screw placed across the grain is calculated according to the formula

$$T_w = 40s_g d m \quad /84/$$

where: s_g - screwing depth of the threaded part of a screw in the element with the thickness a_2 /Fig.28a,b/, cm

In calculations of load bearing capacity of pulled screws values s_g are adopted within the range $4d \leq s_g \leq 7d$. The load bearing capacity of screws placed along the grain is not taken into account.

5.4. Connections with smooth split rings.

5.4.1. Application of rings. Smooth split rings can be applied when:

- a/ connected elements are of timber of at least class III
- b/ connections will be provided in a mechanized way in a specially adapted factory, both as regards equipment and the staff training. In connections of the same structure one should apply rings with the same diameter and width. In tensioned elements each side of a contact should have at least two beams of rings/Fig.29b/

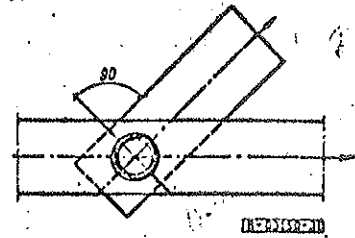

Fig.31

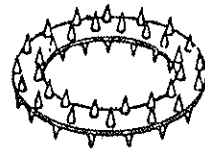

Fig.32

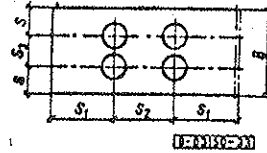

Fig. 33

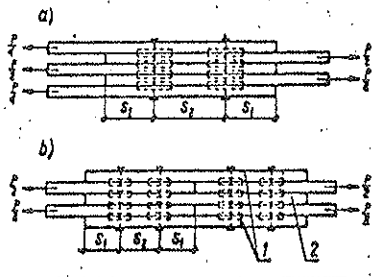

Fig.29

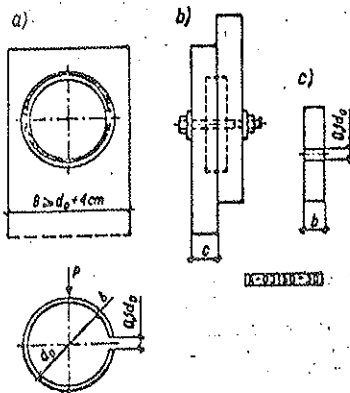

Fig.30

5.4.2. Smooth split rings should be made of flat steel according to PN-677/H-92323 of ordinary coal steel. A slot in a ring should be 0,1d₀/Fig.30c,d/, /d₀ - inside diameter of a ring/.

5.4.3. Way of placing a ring in connections. A ring should be let into each of the connected elements to a depth equal to a half of a ring width. A ring slot should be on the diameter perpendicular to the direction of the force/Fig.31/.

5.4.4. Arrangements of rings. Distance of the ring centre from the face of a connected board or plank should be:

$$S_1 \geq 1,5d_0 \text{ - in tensioned elements}$$

$$S_1 \geq d_0 \text{ - in compressed elements}$$

Distance ring centres should be $S_2 \geq 2d_0$ /Fig.29 and Table 28/.

5.4.5. Load bearing capacity of rings/kG/ is defined according to the formula

$$T = T_{\alpha} m m_p \quad /85/$$

where:

T_{α} - load bearing capacity of a ring acc. to Table 28, kG

m_p - corrector coefficient depending on the number of rings in one series in the direction of the force:
with 1 or 2 rings - $m_p = 1,0$,
with 3 rings - $m_p = 0,85$.

5.4.6. Compressing SCREWS. Elements connected with rings should be pressed to each other with bolts /with washers/ placed in the axis of each ring.

5.4.7. Assortments of smooth rings, SCREWS and washers acc. to Table 28.

5.4.8. Loading of each ring is defined through dividing the total/transferred by the connection/ force:

- a/ in a connection without plates - by the full number of rings/Fig.29a/
- b/ in a connection with plates - by the number of rings on one side of the connection /Fig.29b/.

5.4.9. Calculation of the net cross-section should be performed taking into account the weakenings caused by indentations for rings and a hole for a ~~xxxx~~ bracing acc. to the formulae:

a/ for central elements

$$F_n = F_{br} - b(d_0 + 2\delta) - (c - b)d_{sr} \quad /86/$$

b/ for end elements

$$F_n = F_{br} - \frac{b}{2}(d_0 + 2\delta) - (a - \frac{b}{2})d_{sr} \quad /87/$$

where:

- d_{sr} = diameter of compressing screw, cm
- F_n, F_{br} = ~~xxxx~~ net and gross section, cm²
- δ = thickness of a ring, cm
- $\frac{b}{2}(d_0 + 2\delta)$ - weakening of the section acc. to table 28.
- b - width of a ring, cm
- a - thickness of the end element, cm
- c - thickness of the central element, cm

5.4.10. Smallest dimensions of the sections of connected timber members

a/ width of the member B should exceed the inside diameter of the ring d₀ at least by 4 cm

$$B \geq d_0 + 4 \text{ cm}$$

b/ thickness of the central element c should not be smaller than B + 3 and not smaller than 6 cm

The smallest dimensions of the sections of timber members - acc. to 28

5.4.11. Thickness of inserts and plates. In ring connections inserts should have the same thickness as connected elements and plates - at least 0,75 of this thickness.

5.5. Toothed ring connections

5.5.1. Arrangement of toothed rings.

Distance S₁ of the ring centre from the face of the connected element should not be smaller than 1,5d₀ and distance between ring centres S₂ - not smaller than 2d₀.

Toothed rings should be let into each of the two connected elements to a depth equal to a half of the ring height t.

5.5.2. Bracing SCREWS. Elements connected with rings should be pressed to each other with SCREWS placed in the axis of each ring.

5.5.3. Load bearing capacity of rings.

Toothed rings transfer the force in connections through pressure. Load bearing capacity T_α is defined on the basis of strength test of test connections. In the calculation of connections load bearing capacity of a ring T is defined by the formula

$$T = T_{\alpha} m \quad /88/$$

IX Table 29 shows the assortment and load bearing capacity T_α of toothed rings Geka/Fig.32/.

5.5.4. Application of rings. In contacts of tensioned elements, on each side of a contact at least two beams of rings should be applied. The number of rings in one series should not exceed 6. Rings can be applied in one or two series, in the rectangular arrangement acc. to Fig.33. For toothed rings Geka distance between the first row and the face of an element and between rows - acc. to table 29 col. 12. Distance between series $S_3 \geq d + \frac{1}{2}$. Distance between the first series and the unloaded end $S \geq \frac{d}{2} + 2 \text{ cm}$

where:

- d - inside diameter of the ring /Table 29 col.2/
- t - ring height/Table 29 col.3/
- b, a - width, thickness of a plank /Table 29 col.10 and 11/

5.5.5. Calculation of the net cross-section, taking into account the weakening by rings and the hole for a bracing bolt, is performed acc. to the formulae /86/ and /87/. The weakening by rings Geka - acc. to Table 29 col.6

5.5.6. The smallest dimensions of the cross-section of the members connected with rings Geka - acc. to Table 29 col. 10 and 11.

5.6. Block connections.

5.6.1. Shape of blocks. Blocks with shapes as in Fig. 34 and 35 should closely fit to their sockets, in connected elements. When the connection is in danger of becoming less tight as a result of timber drying, it is advisable to apply wedge-shaped blocks instead of separate blocks/ Fig. 34b/

5.6.2. Dimensions of gains and blocks.

Depth of a gain c should not exceed $1/5$ of the section height h of a connected element/ Fig. 34a/. The smallest gain depth - 2 cm for elements of hardwood sawn timber and 3 cm - for elements of round timber. Length a of a block should be equal or bigger than the fivefold depth of a gain/ Fig.34/ that is $a \geq 5c$

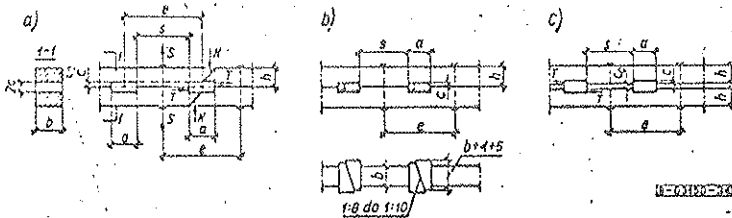

Fig.34

5.6.3. Axial distances e of blocks should be within the limit $2a \leq e \leq 25c$.

5.6.4. Load bearing capacity of blocks. Blocks should be calculated for a shearing force/delaminating/, the value of which on the length of 1 cm on the whole beam width is defined acc. to the formula/18/. Load bearing capacity T /kg/ is calculated according to the formulae

a/ for pressure in the direction of the beam axis $T = cbk$ /89/

b/ for shearing of a block $T = abK_t^{sr}$ /90/

c/ for shearing between neighbouring blocks $T = sbK_t^{sr}$ /91/

where:

- c - depth of a gain, cm
- b - width of connected elements
- K - standard strength at pressure corresponding to K_c or K_d , kg/cm^2
- m - corrector coefficient acc. to 3.11.
- a - length of a block
- K_t^{sr} - standard strength at shearing along the grain or perpendicularly to the direction of the grain/e.g. wedges/ for oak, pine or spruce acc. to the formula /6/, kg/cm^2
- e - distance in the clearance between blocks, cm

5.6.5. Bracing bolts. are calculated for a tensioning force S according to the formulae:

a/ for beam elements in contact with each other/ Fig. 34 a. b./ $S = \frac{Tc}{a}$ /92/

b/ for beam elements which are not in contact with each other/ Fig. 34c/ $S = \frac{T(c+c_0)}{a}$ /93/

where:

- c_0 - distance in clearance between connected elements/ Fig.34c/;
- other symbols acc. to 5.6.4.

5.6.6. Equilateral oblique blocks. In the calculation of load bearing capacity of equilateral oblique blocks, in the formula /91/, length of the shear surface should be assumed acc. to Fig. 35.

5.7. Connections with steel plates with ribs

5.7.1. Application. Connections/joints/ with steel plates/with ribs/ are applied in contacts between tensioned elements / Fig.36/.

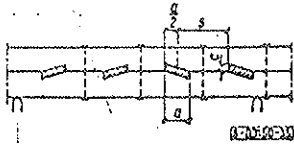

Fig. 35

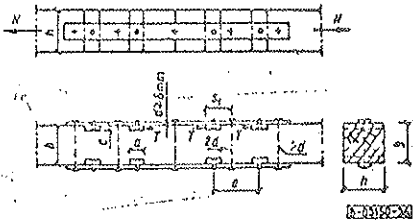

Fig. 36

5.7.2. Construction. Steel plates are composed of two flat steel bars placed on each side of contacting elements, symmetrically to the contact surface. Plates are connected with flat steel ribs with rivets or welding. Ribs are $\lambda \times \lambda$ let into grooves cut in connected elements. The smallest thickness of a plate is 6 mm.

5.7.3. Load bearing capacity of plates. The joint net section $2F_n$ of plates should be

$$2F_n = \frac{N}{K_r} \quad /94/$$

where:

/calculation/

N - design tensioning force in a connection, kG

K_r - strength of steel at tensioning acc. to PN-75/B-03200, kG/cm²

The connection of plates with ribs should be calculated for the force T transferred by each rib.

5.7.4. Dimensions and arrangement of ribs.

a/ thickness of a rib should be within the limit

$$1,5 \text{ cm} \leq c \leq \frac{1}{5} h$$

b/ width of a rib. $b_1 \geq 2,5c$

c/ distance between ribs in clearance $s \leq 10c$
 $s \leq 2h$

d/ number of ribs of one plate on one side of a contact should not exceed 4.

5.7.5. Load bearing capacity of ribs is calculated according to the formulae.

a/ for the pressure to timber

$$T = cbK_t mn \quad /95/$$

b/ for shearing between ribs

$$T = 0,7sbK_t mn \quad /96/$$

where: n - corrector coefficient depending on the number of ribs:

- with 1 or 2 ribs $n = 1,0$
- with 3 ribs $n = 0,9$
- with 4 ribs $n = 0,8$
- other symbols acc. to 5.6.4

5.7.6. Bracing screws are calculated for tensioning for the force S acc. to the formula

$$S = \frac{T(c+d)}{e} \quad /97/$$

where:

T - load bearing capacity of a rib, kG

c - thickness of a rib, cm

b - thickness of a plate, cm

e - distance between rib centres and steel screw centres/fig.36/, cm

5.7.7. Calculation of the net cross-section.

The net cross-section of the connected elements working for tensioning is calculated with regard to the section weakening by the indentation for ribs/fig.36/.

$$F_n = (h-2c)b \quad /98/$$

5.8. Toothed connections.

5.8.1. Frontal gains

5.8.1.1. Width of toothed connected elements /fig. 37/ should not be smaller than 5 cm.

In case when a screw is to be let through an element, its width should not be smaller than 8 cm/fig.37/ and not smaller than $6d$ / d - screw diameter/.

5.8.2. Dimensions of gains should be:

a/ depth r :

in intermediate gains - $r \leq 0,25 h$

in support gains - $r \leq 0,3 h$

but not less than 2 cm - in elements of rectangular section and not less than 3 cm - in elements of round timber; difference the gain height in a double gain $r_2 - r_1$ should exceed or be equal to 2cm;

b/ length of the shearing surface should not be smaller than $1,5h$ or $1,5 \cdot d/d$ - round timber diameter/ and not smaller than 20 cm.

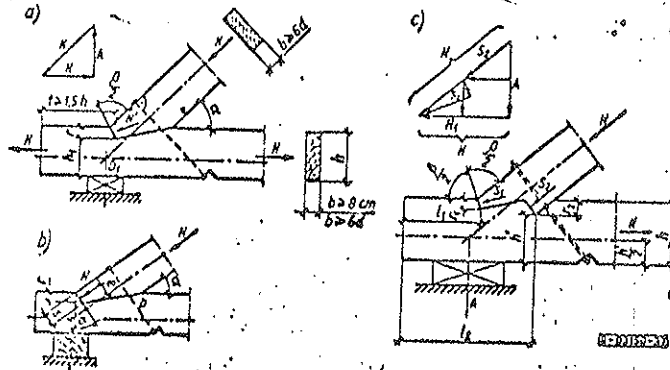

Fig. 37

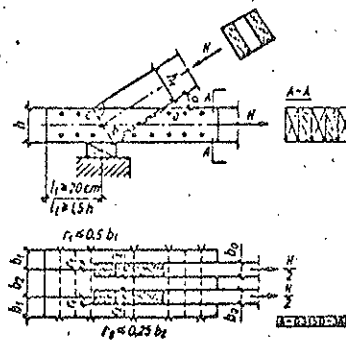

Fig. 38

5.8.1.3. Pressure stress is defined by the formula:

a/ in single gains with the pressure surface on bisectrix/ Fig. 37a/

$$\sigma = \frac{N \cos^2 \frac{\alpha}{2}}{rb} \leq K_{da} \frac{\alpha}{2} \cdot m \quad /99/$$

b/ in single gains with the pressure surface perpendicular to one of the connected elements/ Fig. 37b/

$$\sigma = \frac{N \cos \alpha}{rb} \leq K_{da} m \quad /100/$$

c/ in double gains/ Fig. 37c/

$$\sigma = \frac{S_1}{F_d} \leq K_{da} m \quad \text{and} \quad \sigma = \frac{S_2}{F_d} \leq K_{da} m \quad /101/$$

where: N - design axial force in a compressed member, kG

F_d', F_d'' - pressure surface of the first or second gain, cm²

S_1, S_2 - components of the axial force N of the compressed member, perpendicular to the pressure surface, kG

K_{da} - standard strength at pressure depending on the inclination angle of the pressure surface, kG/cm²

r, b, α - acc. to Fig. 37

5.8.1.4. Shearing stress is defined by formulae

a/ in single gains/ Fig 37a/

$$\tau = \frac{N \cos \alpha}{F_t} \leq k_s^{sr} m \quad /102/$$

b/ in double gains /Fig. 37c/

- in the shear surface at the depth of the first gain

$$\tau = \frac{N \cos \alpha}{F_t'} \cdot \frac{F_d'}{F_d' + F_d''} \leq 0.8 k_s^{sr} m \quad /103/$$

- in the shear surface at the depth of the second gain

$$\tau = \frac{N \cos \alpha}{F_t''} \leq 1.15 k_s^{sr} m \quad /104/$$

where:

$F_t = t b$ - shear surface, cm^2

$F_t' = t_1 b$ - shear surface at the depth r_1 , cm^2

$F_t'' = t_2 b$ - shear surface at the depth r_2 , cm^2

k_s^{sr} - average standard strength acc. to formula/6/.

Other symbols - acc. to 5.8.1.3.

5.8.1.5. Bracing screws. Support gains of trusses/ Fig. 37/ should be protected with bracing bolts with the core diameter d_c /cm/ acc. to the formula

$$d_c = 1.10 \sqrt{\frac{N n_g (60^\circ - \alpha)}{k_r}} \quad /105/$$

where: N - design axial force, kg

k_r - tensioning strength for bolts, kg/cm^2

α - inclination angle of connected elements

5.8.2. Notches 5.8.2.1 Dimensions

a/ depth of the side notch/ Fig. 38/

- with one-sided notch/asymmetrical/ in end plate

$$r = 0.50 b_1$$

- with two-sided notch/symmetrical/ in central plate-

$$r_2 = 0.25 b_2$$

b/ average length of the shear surface: $t \geq 1.5 h$; $t \geq 20$ cm.

In statical calculations length of the shear surface is: $t \leq 10r$.

5.8.2.2. Bracing screws. In notches one should apply horizontal bracing screws.

5.8.2.3. Shearing stresses. With the inclination angles α of connected elements up to 40° , shearing stresses along the grain should be calculated acc. to the formula

$$\tau = \frac{N \cos \alpha}{F_t} \leq k_{sp} m n \quad /106/$$

where:

N - axial force in a compressed member, kg/cm^2

F_t - sum of sheared surfaces, cm^2

k_{sp} - standard strength at shear in notches; for $\alpha \geq 30^\circ$ -

$$k_{sp} = 4.0 \text{ kg/cm}^2$$

for $\alpha < 30^\circ$ - $k_{sp} = 6.0 \text{ kg/cm}^2$

n - coefficient: for $\alpha < 25^\circ$ - $n = 1.0$

for $\alpha = 25^\circ + 40^\circ$ - $n = 0.5 + (40 - \alpha) \cdot 0.02$

5.8.2.4. Pressure stresses should be defined by the formula

$$\sigma = \frac{N \cos \alpha}{2 h_1 (r_1 + r_2) n_g} \leq k_{dc} m \quad /107/$$

where:

h_1, r_1, r_2 - acc. to 5.8.2.1. and Fig. 38

n_g - number of branches

5.9. Clamp connections. Clamp connectors should be used only in secondary connections or in temporary timber structures of square-sawn timber, round timber and planks. Clamps should not be used in structures of timber boards.

5.10. Other types of connectors which have not been discussed in the standard may be used, providing that permission is obtained from scientific authorities/scientific centre/.

Permissible load bearing capacity, one adopts, is the smaller one of the two values:

a/ $\frac{1}{2.25}$ of breaking load

b/ loads, with which the shift of connected elements is 1.5 mm

5.11. Glued connections.

5.11.1. Material

5.11.1.1 Sawn timber. For glued elements one uses pine sawn timber or spruce sawn timber/acc. to the annex/ depending on the category of structural elements/table 6/ For lengths of glued, bent, free-supported elements it is possible to apply, in end quarters of a span, timber of lower classes than in central quarters/ Fig. 39/.

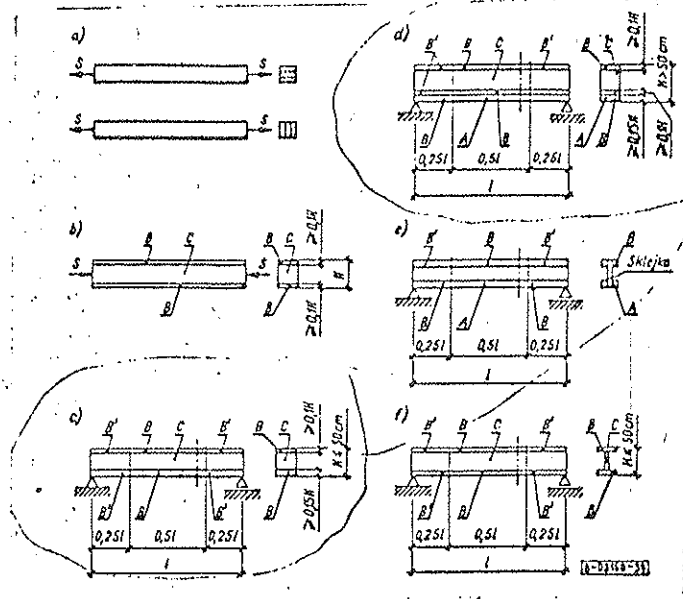

Fig.39

Thickness of sawn timber for glued elements, protected against humidity, should not exceed 5 cm and for unprotected elements - not bigger than 3 cm. For laminated elements, higher than 35 cm, one should not apply thicker boards than 4 cm. In laminated, curvilinear elements with the radius of curvature not smaller than 300 thicknesses of a board, one can use boards with the thickness up to 4 cm, while with the radius not smaller than 200 - boards with the thickness up to 3 cm.

5.11.1.2. Glues. For gluing structures, protected against humidity, it is recommended to apply glues based on synthetic resins such as: urea resins, resorcin resins and phenolic resins. It is possible to use casein glue providing that glued connections are protected against humidity and biological corrosion.

In structures exposed to humidity it is necessary to apply glues based on resorcin resins. Other glues may be applied, if officially accepted by building authorities on the basis of a certificate issued by a scientific centre. Strength at shear of a glued connection for pine or spruce should not be smaller than 70 kg/cm², when dry, and 40 kg/cm², when moist/after 24 hours of soaking/.

5.11.2: Dryness of timber. For glued structures one should apply timber with the dryness/moisture content/ that would meet the requirements of the gluing technology but not exceed 15%/acc. to 2.1.5.1 e/

5.11.3 Conditions of gluing

5.11.3.1. It is permitted to produce glued structures only in specialized factories with a proper equipment and qualified staff. With glued structures it is necessary to ensure structure of materials and technological parameters.

5.11.3.2. Elements should be glued along the grain. Connecting at an angle should be performed in compliance with data in Table 30, depending on the kind of glue.

Table 30. Widths of elements in connections glued at an angle

connections at an angle	The biggest width of a glued element, cm	
	casein	synthetic
90°	8	10
45°	12	15

5.11.3.3. Arrangements of boards with cross-section should correspond with the arrangement in Fig. 40b/

Table 32. Corrector coefficients k_{w1}

beam width cm /Fig. 45b/ a/, 46a/	coefficients k_{w1} for beams with the height H/cm/					
	14;50	60	70	80	100	120 and more
$b < 14$	1,00	0,95	0,90	0,85	0,80	0,80
$b \geq 15$	1,05	1,05	1,00	0,90	0,85	0,80

Height H of girders/two-trapezoidal, laminated/ with the rectangular section is measured at the distance $\frac{z}{4}$ /Fig. 46a/

Table 33. Corrector coefficients k_{w2}

ratio b_1/b	1/2	1/3	1/4
k_{w2}	0,90	0,80	0,75

6.3.3. calculation of glued elements of two different materials/ e.g. timber and plywood/ should be performed with the introduction of substitute values of durability characterization:

a/ coefficient of strength /comparable/

$$W_z = \frac{J_z}{z} \quad /110/$$

b/ moment of inertia /comparable/

$$J_z = J_d + J_{mz} \frac{E_{mz}}{E_d} \quad \text{or} \quad J_z = J_{mz} + J_d \frac{E_d}{E_{mz}} \quad /111/$$

c/ cross-section /comparable/

$$F_z = F_d + F_{mz} \frac{E_{mz}}{E_d} \quad \text{or} \quad F_z = F_{mz} + F_d \frac{E_d}{E_{mz}} \quad /112/$$

d/ statical moment/comparable/

$$S_z = S_d + S_{mz} \frac{E_{mz}}{E_d} \quad \text{or} \quad S_z = S_{mz} + S_d \frac{E_d}{E_{mz}} \quad /113/$$

where:

E_d - coefficient of elasticity of timber, kg/cm^2

E_{mz} - coefficient of elasticity of the used material

J_{mz}, F_{mz}, S_{mz} - durability characterization of substitute materials,

z - distance between the neutral axis and the end edge of the section, cm

Substitute values should be determined in relation to the material used for end layers of an element.

6.3.4. Shear stress at bending is defined by the formulae:

a/ in the neutral axis of the laminated section

$$\tau = \frac{Q S_{br}}{b J_{br}} \leq K_t m \quad /114/$$

b/ in the glued joint, in the contact of a flange with a web or a wall

$$\tau = \frac{Q S_{br}^p}{J_z \sum_i t_i} \leq K'_{td} m \quad /115/$$

c/ in the web or wall in the neutral axis

$$\tau = \frac{Q S_z}{J_z \sum_i \delta_i} \leq K_t^+ m \quad /116/$$

d/ stability of the web

$$\tau = \frac{Q}{b_0 \sum_i \delta_i^2} \leq K_t m \quad /117/$$

where:

= joint width, cm

- standard strength at shear acc. to Table 8

- standard strength of a glued joint

For $\alpha = 90^\circ - K'_{td} = 10 \text{ kg/cm}^2$, for $\alpha = 0^\circ$

$K'_{td} = 7 \text{ kg/cm}^2$; intermediate

values should be interpolated linearly,

- angle between the direction of the grain of the face board /plywood/ and the direction of the flange grain

- distance between flange axes, cm

- thickness of the web or walls, cm

- coefficient of stability of the web or the wall;

for plywood $\varphi_{sk} = \left(\frac{65 \delta_{sk}}{a}\right)^2 \quad /118/$

$\varphi_{sk} = 1.0$ for $a \leq 65 \delta_{sk}$

with a - distance in clearance

between bracing ribs, cm

S_{br}^p - statical moment of the flange section in relation to the neutral axis, cm^3

Q - transverse force on the flange section, kg .

6.3.5. Deflection of timber, glued beams is calculated, taking into account the standard load/without over-load coefficient/, /equally distributed/, according the formulae:

a/ for laminated beams with the variable /on the length/ rectangular section /Fig. 46a I/

$$f = \frac{f_0}{0.15 + 0.85 \frac{H_p}{H}} \quad /119/$$

a/ for laminated beams with I-section/variable on the length/ Fig. 46a II/

$$f = \frac{f_0}{0.4 + 0.6 \frac{h_p}{h}} \quad /120/$$

c/ for beams of boards with sections as in Fig. 45a/, 46b/ and Table 34 /the same on the whole length/

$$f = f_0 \left(1 + \frac{H^2}{L^2} \alpha \right) \quad /121/$$

d/ for beams of boards with I-section or box section, variable on the length, with a web or walls of plywood or hard fibreboards/ Fig. 46b/

$$f \times f_0' = \frac{\left(1 + \alpha \frac{H^2}{L^2} \right)}{0.4 + 0.6 \frac{h_p}{h_s}} \quad /122/$$

where:

f_0 - deflection for free supported beams with constant a constant section, measured in the middle of span

f_0' - deflection of a free supported beam of two different materials/ in the formula J_z used instead of J , cm

h_0, h_p - height in the middle of span and on the support, measured between flange axes, cm

α - corrector coefficient taking into account the influence of shear acc. to Table 34.

L - span of a girder, cm

Formulae /120/ and /122/ should be only used with the ratio $\frac{h_p}{h_0} = 0,25 \div 0,75$.

Table 34. Corrector coefficients α to the formulae /121/ and /122/ to determine the influence of shear stress on the beam deflection

Beam section	Coefficient α for beams with the ratio b_1/b /Fig. 45a/ and 46b/			
	1/2	1/3	1/4	1/8
Of boards:				
I-section	38	50	64	—
T-section /bottom tensioned flange/	31	35	39	—
solid section	35	46	59	—
I- or box section/web or wall of plywood/	—	38	48	90

6.3.6. Wedge contact in the connection on the height of the whole section of a uniform element causes its weakening, which should be taken into account in the calculation of the net section

$$F_n = (1 - n) F_{br} \quad /123/$$

where $n = \frac{b}{t}$ / Table 31/

6.3.7. Impregnation of timber before glueing is permitted, providing that scientific authorities issue a special certificate of permission for the application of given impregnants and glues.

7. STEEL BRACES

7.1. Spaces between hangers. A steel hanger should be suspended to a vault or an arch at spaces not bigger than 5 m.

7.2. Brace ends, in case there are no turnbuckles, should be provided with double nuts and washers with dimensions calculated from the pressure conditions caused by bracing force, with:

a/ for round washers - diameter $D \geq 7d$

b/ for square washers - side $a \geq 6d$

Timber under washers should be impregnated with agents protecting against any kind of biological corrosion.

7.3. Design strength in braces. In case of brace weakening with a thread, design strength is as for SCREWS - acc. to PN-76/B-03200 with the corrector coefficient 0,8.

7.4. Braces of composite section of two or more bars should be designed for design strength reduced by 15% in relation to the one in 7.3.

7.5. Brace screws and bracing SCREWS should be tightened during the period of exploitation, because timber is very likely to shrink. Therefore, screws should have a sufficiently long thread and they should be accessible, to facilitate their tightening.

ADDITIONAL INFORMATION to PN-73/B-03150

1. Essential modifications in PN-64/B-03150.

Measuring of timber structures acc. to the limit states method has been introduced to replace the method of permissible stresses.

2. Counterparts in foreign standards

CSRS ČSN 732050 Projektování dřevěných konstrukcí
RFN DIN 1052/1969 Bl. 1 Holzbauwerke. Berechnung und Ausführung

DIN 1052/1969 Bl. 2 Bestimmungen für Dubelverbindungen besonderer Bauart

CONTENTS

1. INTRODUCTION

- 1.1. Subject of the standard
- 1.2. Application range of the standard
- 1.3. Standards and connected documents

2. MATERIALS

- 2.1. Timber
 - 2.1.1. Timber used in structural elements
 - 2.1.2. Inserts, pins, blocks
 - 2.1.3. Assortments, classification of sawn timber as regards its quality. Requirements
 - 2.1.4. Minimum instantaneous strength of standard samples of pine wood and spruce wood
 - 2.1.5. Dryness of timber
 - 2.1.5.1. Permissible dryness of hardwood
 - 2.1.5.2. Dryness of softwood
 - 2.1.6. Coefficients of elasticity and deformation
 - 2.1.7. Class/quality/ of timber
 - 2.1.8. Timber defects for elements of timber structures
- 2.2. Plywood
 - 2.2.1. Plywood applied in structures
 - 2.2.2. Assortments and classification of plywood
 - 2.2.3. Thickness of plywood
 - 2.2.4. Coefficient of elasticity of plywood
 - 2.2.5. Instantaneous strength of plywood
- 2.3. Fibreboards
 - 2.3.1. Fibreboards
 - 2.3.2. Coefficients of elasticity and deformation E and G
 - 2.3.3. Minimum instantaneous strength of fibreboards
- 2.4. Ancillary materials
 - 2.4.1. Connectors
 - 2.4.1.1. Bolts
 - 2.4.1.2. Nuts for bolts
 - 2.4.1.3. Screws
 - 2.4.1.4. Nails
 - 2.4.1.5. Inserts, plates ect.
 - 2.4.1.6. Structural glues
 - 2.4.2. Impregnating materials and timber derived materials
 - 2.4.3. Materials protecting timber against chemical aggression

3. PROVISIONS FOR CALCULATION AND DESIGNING

- 3.1. General rules
- 3.2. Method of calculation
- 3.3. Load distribution
- 3.4. Categories of structural elements
- 3.5. Weight of trusses G_v
- 3.6. Forces in elements and connections
- 3.7. Deformations of timber structures
- 3.8. Standard strength of timber
 - 3.8.1. Values of standard strengths
 - 3.8.2. Particular cases of standard strengths
 - 3.8.2.1. Standard strength $K_{d\alpha}$ with the pressure at an acute angle to the grain
 - 3.8.2.2. Standard strength $K_{d\alpha}$ with shear at an acute angle to the direction of the grain
 - 3.8.2.3. Standard strength on the wall $K_{d\alpha}$ in connections with uniform stress distribution in shear plane
- 3.9. Standard strength of plywood
 - 3.9.1. Types of standard strengths of water resistant plywood
 - 3.9.2. Standard strength with compression and tension at an angle
- 3.10. Standard strength of fibreboards
 - 3.10.1. Kinds of standard strengths of hard and very hard fibreboards
 - 3.10.2. Strength of fibreboards in higher humidity
- 3.11. Design strength of timber
- 3.12. Way of expressing values in units of measurements of the SI system

4. DESIGNING

- 4.1. Maximum ambient temperature
- 4.2. The smallest net cross-section
- 4.3. Tapering of round timber
- 4.4. Weakening of section
 - 4.4.1. Weakening of section with indentations
 - 4.4.2. Calculation of the section weakened with connectors
 - 4.4.3. Weakening of bent sections
 - 4.4.3.1. Weakening of span
 - 4.4.3.2. Weakening in support
 - 4.4.4. Conditions for disregarding weakenings
- 4.5. System of truss members in truss girders
- 4.6. Tensioned truss members
 - 4.6.1. Stresses in axially tensioned truss members
 - 4.6.2. Plates for tensioned contacts
- 4.7. Bending
 - 4.7.1. Theoretical span of beams
 - 4.7.2. Angle braces and their connections
 - 4.7.3. Spans of beams and purlins supported with bolsters
 - 4.7.4. Bearing reactions
 - 4.7.5. Calculation of bending stresses in a solid beam
 - 4.7.6. Calculation of bending stresses in a composite beam
 - 4.7.6.1. Edge stresses at bending
 - 4.7.6.2. Calculation of bending stresses in composite beams I, II, III
 - 4.7.6.3. Calculation of bending stresses in composite beams IV
 - 4.7.7. Shearing stresses at bending
 - 4.7.7.1. Checking of shearing stresses
 - 4.7.7.2. Calculation of shearing/delaminating forces
 - 4.7.7.3. Number of connectors
 - 4.7.8. Nailed girders
 - 4.7.9. Contacts
 - 4.7.10. Deflection of beams and truss girders
 - 4.7.10.1. Deflection of beams and truss girders with flat bending
 - 4.7.10.2. Deflection of beams with oblique bending
 - 4.7.10.3. The biggest permissible deflection
 - 4.7.10.4. Deflection of continuous beams
 - 4.7.10.5. Structural deflection for special cases
 - 4.7.11. Structural flexion
- 4.8. Single members, axially compressed
 - 4.8.1. Slenderness
 - 4.8.2. Buckling length l
 - 4.8.3. Coefficients of buckling length
 - 4.8.4. Buckling of arches
 - 4.8.4.1. Buckling length l in the arch plane
 - 4.8.4.2. Buckling length l from the arch plane
 - 4.8.5. Buckling length of columns and transoms
 - 4.8.6. Sections of solid, axially compressed members
 - 4.8.7. Coefficients of buckling
- 4.9. Members of composite section, axially compressed
 - 4.9.1. Types of sections of composite, compressed members
 - 4.9.2. Number of parallel seams
 - 4.9.3. Buckling in the plane, perpendicular to seams

- 4.9.4. Buckling in the plane, parallel to scams
- 4.9.5. Moment of inertia of glued members
- 4.9.6. Moment of inertia of columns and frame trusses
- 4.9.7. Calculation of shearing forces
- 4.9.8. External batten plates
- 4.9.9. Cross braces in trussed members of type IV
- 4.9.10. Minimum number of connectors in the column connection
- 4.10. Eccentrically loaded members
- 4.10.1. Eccentrically tensioned members
- 4.10.2. Eccentrically compressed members
- 4.10.3. Number of cuts n of connectors between branches
- 4.11. Bracing
- 4.11.1. Lateral bracing
- 4.11.2. Trusses and braces
- 4.11.3. Stress checking in the compressed flange of a girder
- 4.12. Structural height of girders
- 4.12.1. Structural height H of I- or box beams
- 4.12.2. Structural height H₀ of truss girders
- 4.12.3. Elevation f and structural height h
- 4.13. Centrings
- 4.13.1. Measuring of centrings
- 4.13.2. Number of connectors in centrings

5. CONNECTIONS

- 5.1. Nailed connections
- 5.1.2. Minimum thickness of boards and steel sheets applied in timber nailed structures
- 5.1.2.1. Minimum thickness of boards
- 5.1.2.2. Minimum thickness of steel sheets
- 5.1.2.3. Nails in connections timber-plywood
- 5.1.3. Drilling of holes for nails
- 5.1.4. Arrangements of driven nails
- 5.1.5. Nail driving
- 5.1.6. The smallest number of nails in a connection
- 5.1.7. Load bearing capacity of nails
- 5.1.7.1. Load bearing capacity of a nail in single shear
- 5.1.7.2. Influence of nail driving depth s on the nail load bearing capacity
- 5.1.7.3. Load bearing capacity of nails driven into drilled holes
- 5.1.7.4. Load bearing capacity of nails in connections timber-steel sheet
- 5.1.8. Length of nails
- 5.1.9. Permissible radius of curvature of elements in nail connections
- 5.1.10. Calculation of the net cross-section
- 5.1.11. Pulled out nails
- 5.2. Bolt and screw connections
- 5.2.1. Bolts
- 5.2.2. Screws
- 5.2.3. Arrangements of bolts and screws
- 5.2.4. Number of bolts in tensioned contacts
- 5.2.5. Number of bracing bolts in contacts
- 5.2.6. Number of bolts in joints of truss girders
- 5.2.7. Steel washers
- 5.2.8. Bolt and screw connections
- 5.2.9. Bracing screws
- 5.2.10. Seating of bolts and screws in connections
- 5.2.11. Load bearing capacity of a bolt or a screw in single shear
- 5.2.12. Load bearing capacity of screws at tensioning
- 5.2.13. Load bearing capacity of bolts with the force working perpendicularly to the grain
- 5.2.14. Load bearing capacity of bolts or screws in connections timber-steel sheet
- 5.2.15. Calculation of net cross-section
- 5.3. Connections with screws
- 5.3.1. Types of screws
- 5.3.2. Fixing of timber screws
- 5.3.3. Timber screws working for bending and pressure
- 5.3.4. Arrangements of screws

- 5.3.5. Minimum number of screws in a connection
- 5.3.6. Calculation of net cross-section
- 5.3.7. Timber screws working for pulling
- 5.3.7.1. Arrangement of screws
- 5.3.7.2. Load bearing capacity of screws at pulling
- 5.4. Connections with smooth split rings
- 5.4.1. Application of rings
- 5.4.2. Smooth split rings
- 5.4.3. Way of placing ring in a connection
- 5.4.4. Arrangements of rings
- 5.4.5. Load bearing capacity of rings
- 5.4.6. Compressing bolts
- 5.4.7. Assortments of smooth rings, bolts and washers
- 5.4.8. Loading of each ring
- 5.4.9. Calculation of the net cross-section
- 5.4.10. Smallest dimensions of sections of connected timber members
- 5.4.11. Thickness of inserts and plates
- 5.5. Toothed ring connections
- 5.5.1. Arrangement of toothed rings
- 5.5.2. Bracing bolts
- 5.5.3. Load bearing capacity of rings
- 5.5.4. Application of rings
- 5.5.5. Calculation of net cross-section
- 5.5.6. Smallest dimensions of the cross-section of the members connected with rings Geka

- 5.6. Block connections
- 5.6.1. Shape of blocks
- 5.6.2. Dimensions of gains and blocks
- 5.6.3. Axial distances e of blocks
- 5.6.4. Load bearing capacity of blocks
- 5.6.5. Bracing bolts
- 5.6.6. Equilateral oblique blocks
- 5.7. Connections with steel plates with ribs
- 5.7.1. Application
- 5.7.2. Construction
- 5.7.3. Load bearing capacity of plates
- 5.7.4. Dimensions and arrangement of ribs
- 5.7.5. Load bearing capacity of ribs
- 5.7.6. Bracing screws
- 5.7.7. Calculation of the net cross-section
- 5.8. Toothed connections
- 5.8.1. Frontal gains
- 5.8.1.2. Dimensions of gains
- 5.8.1.3. Pressure stress
- 5.8.1.4. Shearing stress
- 5.8.1.5. Bracing screws
- 5.8.2. Notches
- 5.8.2.1. Dimensions
- 5.8.2.2. Bracing screws
- 5.8.2.3. Shearing stresses
- 5.9. Clamp connections
- 5.10. Other types of connectors
- 5.11. Glued connections
- 5.11.1. Material
- 5.11.1.1. Sawn timber
- 5.11.1.2. Glues
- 5.11.2. Dryness of timber
- 5.11.3. Conditions of glueing
- 5.11.3.1. Glued structures
- 5.11.3.2. Glueing of elements
- 5.11.3.3. Arrangements of boards with cross-section
- 5.11.3.4. Arrangements of boards in glued elements wider than 20 cm
- 5.11.3.5. Contacts of glued elements
- 5.12. Connections with various connectors
- 5.12.1. Conditions for the cooperations of connectors

6. CALCULATION OF GLUED STRUCTURES

- 6.1. Conditions of shaping sections
- 6.2. Structural height of beams
- 6.3. Calculation of glued elements
 - 6.3.1. Glued elements
 - 6.3.2. Stress in bent beams
 - 6.3.3. Calculation of glued elements of two different materials
 - 6.3.4. Shear stress at bending
 - 6.3.5. Deflection of timber glued beams
 - 6.3.6. Wedge contact in the connection
 - 6.3.7. Impregnation of timber

7. STEEL BRACES

- 7.1. Spaces between hangers
- 7.2. Brace ends
- 7.3. Design strength in braces
- 7.4. Braces of composite section
- 7.5. Brace screws and bracing screws

ADDITIONAL INFORMATION

- 1. Essential modifications in PN-64/B-03150
- 2. Counterparts in foreign countries

ANNEX

Permissible flaws of sawn timber in elements of timber structures

INTERNATIONAL COUNCIL FOR BUILDING RESEARCH STUDIES AND DOCUMENTATION

WORKING COMMISSION W18 - TIMBER STRUCTURES

THE RUSSIAN TIMBER CODE
Summary of Contents

Bruxelles

October 1977

REGULATIONS AND STANDARDS OF CONSTRUCTION

Chapter 4

Calculation Standards for Wooden Constructions

1. General

Subject : Supporting wooden structures, beam calculations.

Standards established in terms of :

- utilisation
- fabrication
- transport
- erection.

Also in terms of the type of construction.

Table 1.

Classification of constructions in terms of their hydrometrical and thermic characteristics.

2. Raw Materials

Table 2.

Type of wood that must be used in the construction of supporting elements.

Table 3-4

Characteristics of each type of wood.

Table 5.

Maximum moisture content of the wood at the end of its utilisation.

Table 6.

Relative density required for different kinds of construction and different types of wood.

Table 7.

Characteristics of glues in terms of their utilisation.

....

3. Characteristics of Wood

3.1 Table 8.

Admissible stress of resinous woods (pine and fir) in construction types A1, A2 and B1.

3.2 Tables 9-10-11-12-13

Coefficients for multiplying the stress of Table 8 to obtain the admissible stress :

- for other types of wood (Table 9)
- for other uses (Table 10)
- in order to take into account additional charges (Table 11)
- for curved elements (Table 12)
- for hydraulic or thermic installations. (Table 13)

3.3 Table 14

Admissible stress for plywood.

3.4 Admissible stress for steel.

3.5 Modulus of elasticity :

- principles of modulus
- multiplying coefficient for other constructions (Table 10)
- principles of modulus of elasticity for plywood.

3.7 Principles of Calculations

- static calculations
- calculations for deformation.

4. Calculation of the Elements of a Wooden Construction

Tension and compression - Axial

4.1 Tension

4.2 Compression

4.3 Calculation of a coefficient for buckling.

4.4 Calculation of λ .

4.5 Calculation of buckling length.

4.6 Calculation of λ of compound elements.

4.7 Bending

4.8 Bending of arcs.

4.9 Bending of glued arcs.

4.10 Calculation of the shear of arched elements.

4.11 Number of bonds.

Compression and Tension - Non axial

4.13 Tension

4.14 Compression.

4.15 Compression of compound elements.

4.16 Number of bonds.

4.17 Compound Elements Constricted between Bars with Unequal Charges

4.18-4.21 Calculation of the buckling length and the deflexion of compound elements.

4.22 Principles of calculations for glued elements.

5. Assembly Calculations

5.1 -5.3 General.

5.1 Glued joints.

5.4 -5.6 Scarf joints.

5.7 -5.8 Other joints.

Joints Assembled with Haunchs

Fixed Joints

5.10 Frontal Mortice

5.11 Calculations of the shear of morticed assemblies 1 and 2.

5.13 Calculations of mortice at local compression.

Assembly by Cylindrical Dowels

a) General

5.14 Admissible stress effort parallel to fibres - Table 20 (Principles for stress).

5.15 Resistance of bolts of oak or steel, stress not parallel to fibres.

Principles of multiplying coefficient for stress. Table 21.

5.16 Resistance of dowels to other woods and other constructions.

b) Dowels of steel and oak.

5.19-5.20 Positioning

c) Calculation and positioning of nails working against shear (5.21-5.24).

5.25-5.26 d) Calculation of the positioning of screws working against shear.

5.27-5.29 Assemblies with Nails Working Against Extraction

5.30 Assemblies with screws working against extraction.

6. Fundamental Regulations for Calculations

General

6.1 Materials used :

- 2 part beams.
- Beams with variable inertia.
- Compound glued trusses.
- Triangulated arcs.
- Beams and arcs glued.
- Constructions in plywood.
- Plywood panels.

6.2 Deformation - Table 22

6.3 Maximum deflexion - Table 23

6.4 Calculation of the resistance of bars.

6.5 Deformations due to variations of temperature.

6.6 The taking into account of types of friction.

Imperatives for Construction

6.8 Recommendations.

- a) Moisture content of glued woods.
- b) Suitable woods.
- c) Splicing of elements under tension.
- d) Splicing of compressed elements.

6.9-6.13 Utilisation of elements showing symmetry.

6.14-6.17 Calculation methods and principles.

6.18 Compound beams.

Trusses

6.19 Ratio height/span.

6.20 Length taken into account in calculations.

6.21 Webs on triangulated trusses.

6.22 Metal trusses.

Arcs and Curves

6.23 Calculations

6.24 Ratio deflexion/span.

6.26 Calculation of plates.

7. Durability Conditions

7.1 Protection against biological and chemical agents.

7.2 Protection against moisture.

7.3 a) Protection against infiltration.

b) Thermic and vapour isolation.

c) Drying of wood for interior use.

7.4 Ventilation.

7.5 Panel drying.

7.6 Covering of panels.

7.7 Antiseptic treatment.

7.8 Superficial protection for glued elements.

Use of Wood in Cases of Agression from Chemical Agents

7.10-7.11 Use of resinous woods.

7.12 Protection by varnishing.

7.13 Glued elements in a corrosive atmosphere.

7.14 Recommendations for resistance against a corrosive atmosphere.

7.15 Use of plywood.

Characteristics of Wood and Plywood

Table 24 and 25 - Admissible stress.

Reminder of the resistance of pine and fir to 15% humidity. CF Table 3 and 4.

Table 25 - Plywood resistance.

INTERNATIONAL COUNCIL FOR BUILDING RESEARCH STUDIES AND DOCUMENTATION

WORKING COMMISSION W18 - TIMBER STRUCTURES

DRAFT RESOLUTIONS OF ISO/TC 165

Bruxelles

October 1977

Draft Resolutions of TC 165 meeting in London 1977-09-22+23.

1. Title of TC 165

The Secretariat of TC 165 is requested to submit to the Central Secretariat of ISO, for adoption by the ISO Council, the following title for TC 165:-

in English: TIMBER STRUCTURES
in French: STRUCTURES EN BOIS

2. Scope of TC 165

The Secretariat of TC 165 is requested to submit to the Central Secretariat of ISO, for adoption by the ISO Council, the following scope proposed for this committee:-

Standardization concerning the design of loadbearing structures of timber, wood-products and appropriate related lignocellulosic fibrous materials.

The prime concern of the technical committee will be the preparation of an International Standard comprising the technical requirements for the design together with such additional requirements, regarding the materials and the work of construction, necessary to safeguard the validity of design assumptions made or implied.

The standard shall be formulated in such a manner that it gives the greatest freedom for design and construction compatible with satisfactory technical performance and safety over the life of a structure.

The standard shall refer to necessary supporting standards, in particular regarding test methods necessary for the verification of stipulated requirements. The preparation of such supporting standards, should only be undertaken by this technical committee if they do not lie within the field of work of an existing technical committee or if such technical committee is not in a position to provide them.

3. Organisation of the work of TC 165

TC 165 has agreed to organize its work as follows:

The work shall, where applicable, build on the work and results of existing ISO/TCs with which the necessary liaison must be established to avoid duplication of work and to ensure the best distribution of the work involved. Relevant in this respect are the present TCs 55, 59, 89, 139 and 151.

As far as basic and general principles are concerned, the work shall be based on the work and results of ISO/TC 98, Bases for Design of Structures, with which committee a close liaison shall be maintained.

CIB working group W18 has agreed to prepare the first drafts for TC 165. Close liaison shall be maintained with this working group.

To the extent that this is not already secured through the co-operation with CIB W18, liaison shall further be established with other relevant organisations working within the scope of the committee, for example the CEB, the CECM, the EEC, the FEMIB/Sous-Commission "GLULAM", the RILEM and the UN-ECE.

Projets de résolution de la réunion TC 165 en Londres 1977-09-22+23.

1. Titre du TC 165

Le Secrétariat du TC 165 est prié de soumettre au Secrétariat Central de l'ISO pour adoption par le Conseil d'ISO le titre suivant du TC 165:

en anglais: Timber Structures
en français: Structures en Bois

2. Domaine des travaux du TC 165

Le Secrétariat du TC 165 est prié de soumettre au Secrétariat Central de l'ISO pour adoption par le Conseil de l'ISO le domaine des travaux suivants du TC 165:

Normalisation de la conception des structures portantes en bois, en produits à base de bois et en autres matières fibreuses ligno-cellulosique appropriées.

L'objet principal du Comité technique est de préparer une norme internationale sur les exigences techniques relatives à la conception et, dans la mesure où elles sont nécessaires pour satisfaire les hypothèses de calcul, sur celles des matériaux de construction et de leur mise en oeuvre.

La norme doit être conçue de manière telle qu'elle laisse la plus grande liberté de conception et de construction compatible avec une sécurité, une aptitude à l'emploi et une durabilité satisfaisantes d'une structure.

La norme doit faire référence aux normes de base, en particulier à celles sur les méthodes d'essais, nécessaires pour vérifier les exigences spécifiées. La préparation de telles normes de base, ne doit être entreprise par ce Comité technique que si elle n'entre pas dans le domaine des travaux d'un Comité technique existant ou ce dernier comité n'est pas en mesure de les fournir.

3. Organisation du travail du TC 165

Le ISO/TC 165 est d'accord pour organiser son travail dans les conditions suivantes:

Le travail doit être, s'il y a lieu, basé sur les études et résultats des Comités techniques ISO existants avec lesquels la liaison nécessaire doit être établie pour éviter une duplication des efforts et assurer la meilleure distribution du travail envisagée. Les Comités techniques concernés sont actuellement les TC 55, 59, 89, 139 et 151.

En ce qui concerne les principes généraux de base, le travail doit être basé sur les études et résultats de l'ISO/TC 98 "Bases du calcul des constructions" avec lequel une liaison étroite doit être maintenue.

La Commission W18 du CIB a accepté d'entreprendre la rédaction d'un avant-projet de norme. Une liaison étroite doit donc être assurée avec ce groupe.

4. List of contents of CIB W18 draft

CIB W18 is requested to submit to the secretariat of TC 165 the proposed list of contents of its draft indicating the chapters already completed and those in course of preparation.

The Secretariat of TC 165 is to submit this list to the members of TC 165, inviting their comments and suggested order of priority.

The Secretariat will decide, if necessary, to convene the committee, to discuss the comments received, in order to establish the programme of work for the committee.

5. Testing of mechanical joints

TC 165 agreed to postpone the date for the receipt of comments on document 165 N 13 from 31st October to 31st December 1977. TC 165 noted that appendix A of that document should be excluded for the present. The timetable for further drafting-work on this subject will depend on the replies received by the secretariat in connection with the consultation envisaged in resolution no. 4 concerning the choice of priorities.

6. Testing of structural plywood

TC 165 agreed that before any decision concerning the method of studying this problem, consultation shall be undertaken with the CIB W18/RILEM committee, requesting them

- a. to study in liaison with TC 89, 139 and 151 the possibility of generalizing the method of document N14 to cover also other types of panels,
- b. to submit the present draft standard to ISO/TC 139 to determine whether such a draft can be accepted and included in that committee's work in accordance with the priorities of TC 165.

7. Tests on structural timber

TC 165 agreed that before any decision concerning the method of studying this problem, ISO/TC 55 shall be consulted to determine its views on document 165 N15 and whether it can accept such a draft as the basis for study in its programme of work in accordance with the priorities of TC 165.

8. Chairmanship of TC 165

TC 165 decided to nominate Mr. Hans J. Larsen, Denmark, as chairman for the next three years. The secretariat of TC 165 is requested to submit this nomination to ISO Central Secretariat for appointment by ISO Council.

Pour autant que ceci ne soit pas déjà assuré à travers la coopération avec la CIB W 18, une liaison doit ultérieurement être établie avec d'autres organisations travaillant dans le même domaine que le Comité, par exemple, la Commission Economique pour l'Europe, le CEB, le RILEM, le FEMIR/Sous-Commission "GLULAM", la CCE et le CECM.

4. Sommaire du programme du CIB W18

Le CIB W18 est prié d'adresser au Secrétariat du TC 165 le sommaire de son programme en précisant les chapitres qui sont terminés et ceux qui sont en cours d'études.

Le Secrétariat du TC 165 est chargé de soumettre le sommaire aux membres du TC 165 en leur demandant leurs remarques et l'ordre de priorité qu'ils proposent pour leur étude. Il attendra au Secrétariat du TC 165 de réunir, le cas échéant, le Comité technique pour discuter des réponses reçues en vue d'établir le programme de travail du Comité.

5. Essais des joints mécaniques

Le TC 165 est d'accord pour reporter la date de clôture de l'enquête par correspondance sur le document 165 N 13 du 3 octobre au 31 décembre 1977. Le TC 165 a noté que l'appendix A de ce document doit être exclu pour le présent. Le calendrier de la poursuite de l'étude de ce sujet dépendra des réponses reçues par le secrétariat lors de la consultation prévue par la résolution no. 4 pour ce qui concerne le choix des priorités.

6. Essais des contre-plaqués de construction

Le TC 165 est d'accord pour qu'avant de prendre toute décision concernant la manière d'étudier ce problème une consultation soit menée auprès du comité CIB/RILEM à fin

- a. qu'il étudie en liaison avec les comités ISO/TC 89, 139 et 151 la possibilité de généraliser la méthode du document 165 N 14 à d'autre panneaux,
- b. qu'il soumette à l'ISO/TC 139 le présent document pour connaître son avis sur le contenu de ce document et son accord pour l'inclure à son programme de travail selon les priorités qui seront décidées par le TC 165.

7. Essais du bois de construction

Le TC 165 est d'accord pour qu'avant de prendre toute décision concernant la manière d'étudier ce problème, l'ISO/TC 55 soit consulté pour connaître son avis sur le contenu du document 165 N 15 et son accord pour l'inclure comme base d'étude à son programme de travail selon les priorités qui seront décidées par le TC 165.

8. Présidence du TC 165

Le TC 165 a proposé d'élire M. Hans J. Larsen, Danemark, comme président permanent pour les trois prochaines années. Le secrétariat du TC 165 est prié de soumettre cette candidature au Secrétariat Central de l'ISO pour accord du Conseil de l'ISO.

